



# MI-909

## Digital Wireless Stereo IEM System





# Industry's first

## Digitally Encrypted Wireless Stereo IEM System

MI-909 is an industry first, professional quality digital wireless stereo IEM system. Featuring digitally encrypted technology with unparalleled digital audio performance and transmission reliability, the superior frequency response characteristics of the MI-909 from 20Hz to 15 kHz clearly exceed those of analog systems. Combining DSP & digital diversity technologies, this upgraded MI-909 system has advanced features and functions that supersede its competitors.

The key components of the MI-909 IEM system include the MI-909R ultra-compact bodypack receiver and MI-909T rack transmitter.



# MI-909 Digital Wireless Stereo IEM System

## MI-909R Digital Stereo Bodypack Receiver

### Front Panel



### Rear Panel



### Top View



### Battery Insertion



# MI-909 Digital Wireless Stereo IEM System

## MI-909R Digital Stereo Bodypack Receiver

### Features

1. Industry's most compact and smallest housing.
2. Featuring a lightweight, yet rugged, magnesium & glass-fiber reinforced plastic case for stage applications.
3. Backlit LCD screen with superior features and advanced function settings.
4. Dual-antenna diversity design enhances RF signal stability and extends transmission range.
5. Dual unbreakable soft antennas.
6. Selectable stereo, balanced, mono & mixed output modes.
7. Selectable EQ settings.
8. Fast and easy menu controls and indicators accessed by three buttons.

### Specifications

Frequency Range	480~824 MHz (country dependent)
Bandwidth	64 MHz
Channel Grid	25 kHz
Preset Frequency	12 non-interference compatible frequencies in group 1-10. 16 non-interference compatible frequencies in group 11-16. 16 user-defined frequencies can be stored in group 18. 216 preset frequencies in total.
Receiving Mode	Digital diversity receiving
Oscillation Mode	PLL Synthesized
Frequency Stability	± 0.005% (-10~+60°C )
Channel Set-Up	ACT Sync
Modulation Type	Digital modulation
Sensitivity	10 μ V input level, S/N > 90dB (stereo)
Spurious Emissions	< 4 nW
T.H.D.	0.1% @ 1 kHz
Max. S/N ratio	95 dBA
Frequency Response	20 Hz ~ 15 kHz (stereo)
Stereo Separation	> 95 dB
Volume Control	126 dB (1dB step)
LCD Display	AF/RF meters, Battery status, Group & Channel, R/L balance
Output Jack	3.5 mm Ø stereo earphone jack
Output Power	Left/Right × 120 mW @ 16 Ω
Earphone Impedance	≥ 16 Ω
Battery Type	2 AA alkaline
Current Consumption	Approx. 170 mA
Operating Time	Approx. 8 hours (moderate volume)
Dimensions (W × H × D)	63 × 82 × 23 mm / 2.6 × 3.2 × 0.9 "
Net Weight	Approx. 98 g / 3.5 oz
Transmitter	MI-909T
Operating Temperature	-10~+60°C
Note	Refer to actual product in the event of product description discrepancy. Frequency range and maximum deviation comply with the regulations of different countries.

# MI-909 Digital Wireless Stereo IEM System

## MI-909T Digital Stereo Transmitter



### Rear Panel

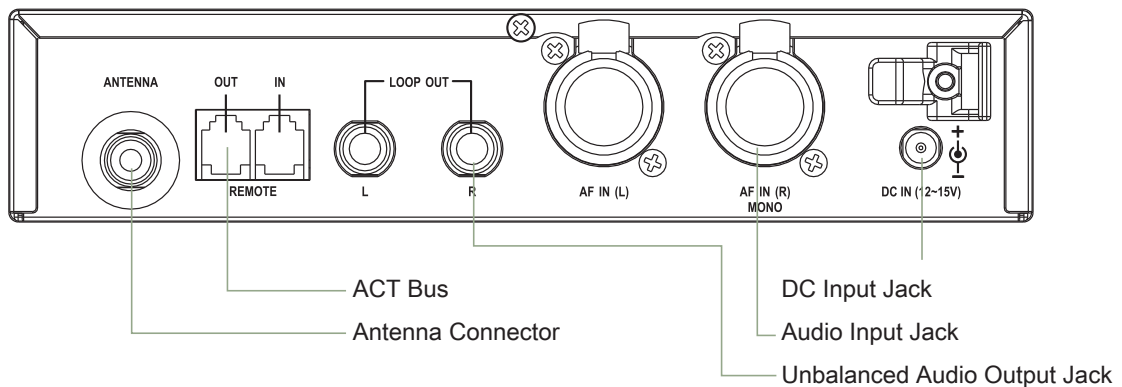

# MI-909 Digital Wireless Stereo IEM System

## MI-909T Digital Stereo Transmitter

### Features

1. EIA-standard half-rack 19" metal case, LCD screen display, rotary control knob for advanced menu settings and dual audio LED indicator lockable front panel.
2. Up to 16 compatible channels within the same frequency group.
3. Selectable encryption keys with scroll or static setting for single or multiple receivers.
4. Selectable HI, LOW or OFF (mute) output power.
5. High dynamic range, stereo audio inputs and able to withstand the maximum output levels of professional audio mixers.
6. Built-in DSP 3 band  $\pm 9$  dB EQ settings for audio modifications.
7. Free Scan selects an open, interference-free transmitter frequency and ACT syncs the transmitter and receiver frequencies automatically.
8. Ideal for professional multi-language interpretation system and installation applications.

### Specifications

Frequency Range	470~664 MHz, 672~960 MHz (country dependent)
Bandwidth	64 MHz
Oscillation Mode	PLL Synthesized
Channel Grid	25 kHz
Frequency Stability	$\pm 0.005\%$ (-10~+60°C)
Modulation Type	Digital modulation
Output Power	Low <10 mW   High <100 mW switchable (country dependent)
Spurious Rejection	< 4 nW
Frequency Response	20 Hz ~ 15 kHz (stereo)
T.H.D.	< 0.1% (at 1 kHz)
ADC Dynamic Range	112 dBA
Stereo Audio Input	6.3 mm $\varnothing$ Phone Jack $\times$ 2, XLR, 6.3 mm $\varnothing$ Combo Jack
Max. Input	> +26 dBu, Selectable Line / Mic level
Audio Input Adjustment	0~-30 dB, 3 dB step
Earphone Output	6.3 mm $\varnothing$ Stereo Phone Jack with volume control
Earphone Output Impedance	$\geq 16 \Omega$
Network Interface	RJ-11 $\times$ 2, proprietary MIPRO ACT-BUS
Antenna Connector	TNC (50 $\Omega$ impedance)
Power Supply	DC 12~15V
Dimensions (W $\times$ H $\times$ D)	210 $\times$ 44 $\times$ 206 mm / 8.3 $\times$ 1.7 $\times$ 8.1 "
Weight	Approx. 1.1 kg / 2.4 lbs
Note	Refer to actual product in the event of product description discrepancy. Frequency range and maximum deviation comply with the regulations of different countries.

# MI-909 Digital Wireless Stereo IEM System

## High Performance Isolation Earphones

### E-8S Standard Earphones

New E-8S earphones provide outstanding sound quality and excellent isolation to suppress high ambient noise levels. They feature an 8 mm dynamic driver with a 20 Hz ~ 20 kHz frequency response and can be fitted with any of the three provided earbud covers for a custom fit and comfort.



1. 8 mm high efficient driver.
2. In-ear, closed-back design with S/M/L earbud covers.
3. 1.5 meter rugged cable.
4. 3.5 mm Ø gold-plated stereo connector.
5. 106 dB SPL/mW.
6. 16 Ω @ 1 kHz nominal impedance.
7. 20 Hz ~ 20 kHz frequency response.
8. Noise isolation > 25 dB.
9. Approx. 16 grams (0.5 ounce) cable included.
10. Operating temperature -15° C to +60° C.

### E-8P Professional Earphones

The E-8P professional earphones are designed for stage monitoring. They deliver full-range sound and are ergonomically built with an adjustable ear hook design for a comfortable, personalized fit and invisibility.



1. Ear canal design for easy earplug placement.
2. Subminiature balanced armature drivers.
3. 1.5 meter ultra durable cable and exterior in beige.
4. 3.5 mm Ø gold-plated stereo connector.
5. Sensitivity >116 dB (1 kHz).
6. 125 dB SPL (1 kHz).
7. 30 Ω @ 1 kHz nominal impedance.
8. 35 Hz ~ 20 kHz frequency response.
9. Noise isolation > 23 dB.
10. Approx. 18 grams (0.6 ounce) cable included.
11. Operating temperature -15° C to +60° C.





**MIPRO Electronics Co., Ltd**

Headquarters : 814 Pei-Kang Road, Chiayi, 60096, Taiwan  
Tel : +886.5.238.0809 Fax : +886.5.238.0803  
www.mipro.com.tw mipro@mipro.com.tw