

A 48

DMX Lighting Console

User's Manual

Ver 1.07

CODE ELECTRONIC CO., LTD.

Introduction

CODE A48 is a universal DMX lighting console. It is able to control any dimmer directly, which follows the same protocol, to build up a digital lighting system. It can save light scene and edit chase programs. Internal chase programs, which were set in CODE A48 by manufacturer, can be used directly. 1 manual scene, 12 submaster scenes and 1 chase program can be performed at the same time. CODE A48 is suitable for small TV studio as well as small show, small dancery, taproom and so on.

Functions and Specifications

- DMX512/1990 standard.
- 48 dimmer channels.
- 24 channels slider x 2 pages, channel master control.
- 12 submaster sliders x 3 pages.
- 36 scenes capability within 3 pages.
- 24 chases up to 80 steps in a chase program.
- Chase speed can be controlled manually (0.3s~10s/step) or triggered by music rhythm.
- Cross control of brightness gradual change.
- Music signal can be inputted from audio line (-10~+10dB self adapted) or a internal microphone.
- 1 manual scene, 12 submaster scenes and 1 chase program can be performed at the same time.
- Flash control for submaster.
- Master level control.
- DMX output module with optical isolated.
- DMX signal output connector: XLR-D3F.
- Music input: 1/4" unbalanced mono jack.
- Power: AC 100~240V, 50-60Hz, 8W.
- Size: 482mm X 310mm X 95mm
- Weight: 5.2Kg

Cautions for safety

- A48 lighting console must be connected to the earth line to ensure the safety.
- When A48 lighting console and dimmer are working, don't plug in or pull out DMX512 data cable.
- Do not expose it to a humid environment. Do not let any liquid splash to the lighting console.
- The lighting console is precision electric equipment. Please pay attention to moistureproof protection and dustproof protection.

Installation

Contents in the package of A48 lighting console:

- A48 lighting console x1
- Power supply line x1
- Certification of QC x1
- User's Manual x1

A48 lighting console adopts international standard 19" 4U installing structure. It can be embedded in operation board or directly installed in 19" shelf or cabinet. Before the power supply is connected, please check whether the voltage is in normal range and whether the power supply socket is connected to the earth line.

Panel Unit

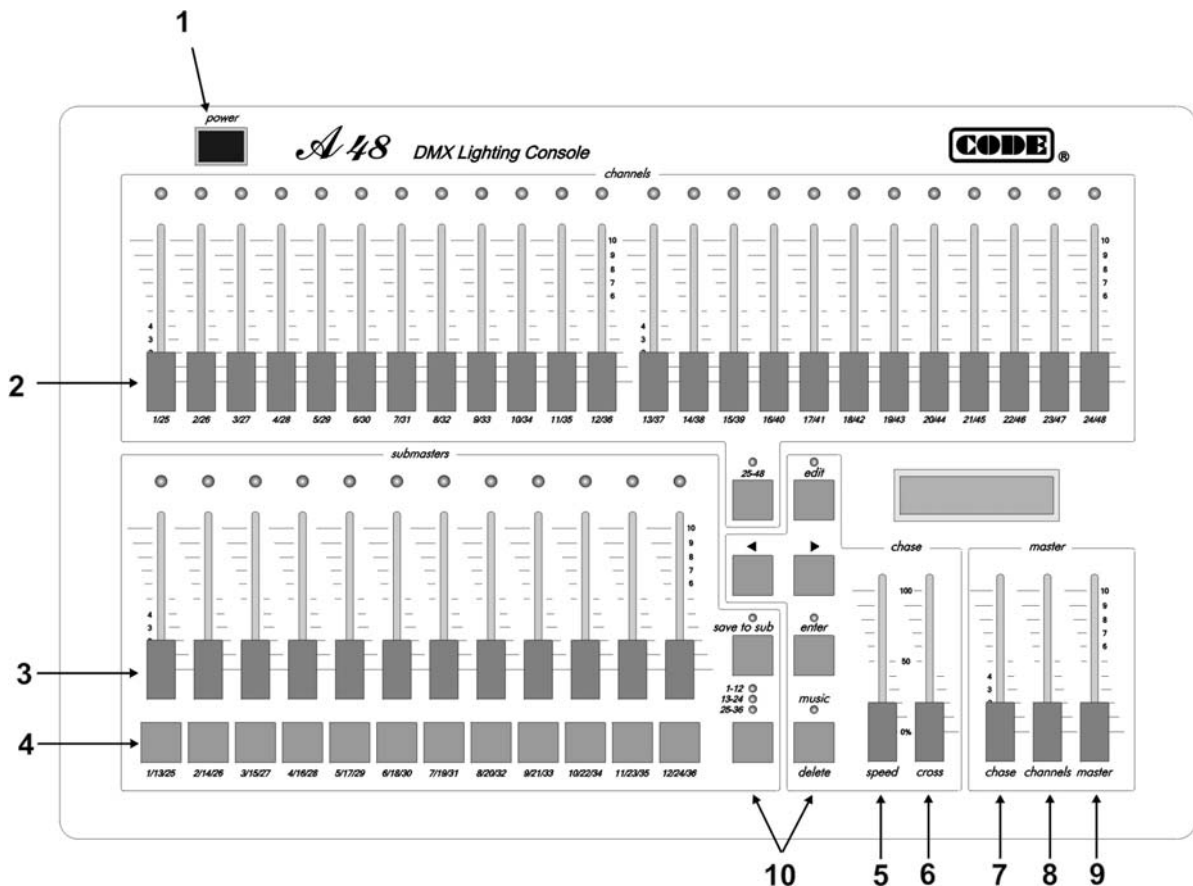

1. Power switch

Turn off or turn on the power of A48 lighting console. The console can remember the last state automatically and run it continually next time.

2. **Ch1~Ch24 / Ch25~Ch48 Channel slider**

Used for control the value of *Ch1~Ch24* or *Ch25~Ch48* directly.

3. **Submasters slider**

Light scene is the combination of brightness value of each channel.

Each submaster slider can store a light scene. Move the slider can change the level of light scene.

The brightness ratio of light scene1-12 can be controlled directly by submaster slider1-12. Submaster slider 13-24 or 25-36 can be switched by page key.

4. **Flash key**

Implement flash control of submaster. Pressing a number key made the corresponding submaster slider to the maximum. Releasing the number key will resume the brightness set by the corresponding submaster slider.

5. **Speed Slider**

Adjust the chase speed.

6. **Cross Slider**

Adjust the cross speed.

7. **Chase output slider**

Allows to set the brightness of the chase program.

8. **Manual output slider**

Allows to control the brightness ratio of CH1-CH48.

9. **Master slider**

General output level control, used to adjust the overall level of all submaster sliders and all channels.

10. **Function key**

- **Page key for 25~48 channel**

This button is used to switch the page of dimmer channel. When the key's LED is off, the channel slider control 1-24. When it is on, it will control the channel of 25-48.

- **Edit key**

Pressing this button for 2 seconds will entry or exit chase programming state.

- **Direction key**

This buttons can change the chase number, the program step and the direction of chase program.

- **Save to Sub key**

Store the current brightness values of every channel to submaster slider set by user.

- **Enter key**

When working in normal mode, this button is used to confirm the chase number cooperated with the direction key. By holding this button, A48 allows to change the direction of chase using the

direction button. In programming mode, it is used to enter the next stage.

- **Page key for 1~12, 13~24, 25~36**

This button is used to switch the page of submaster. The current page is indicated by the corresponding LED.

- **Music/Delete Key**

1. When working in chase mode, if the key's LED is on, the chase program is controlled by the rhythm of music. When this function is disenabled, the speed of chase is controlled by the speed slider.
2. By holding the "Enter" key and press this key will clear the current value of 1-48 channel.
3. In chase programming mode, press this key will clear the current step of chase.

Rear of A48

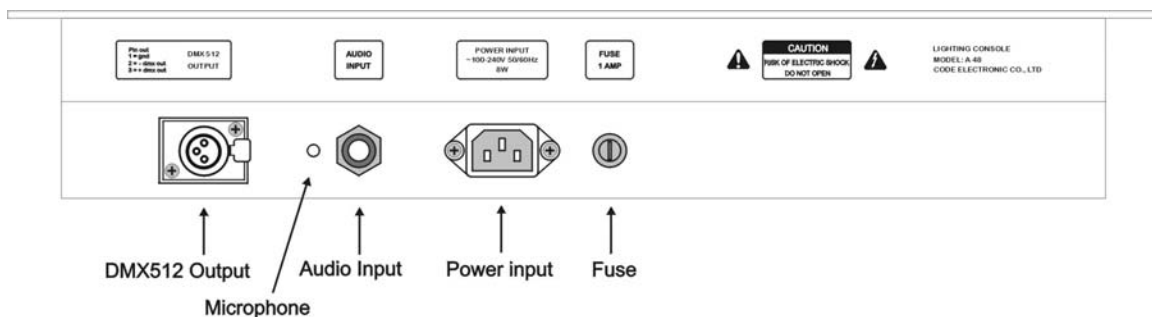

Connection of power supply

Power supply line has a three-foot plug, which follows the standard of P. R. China. The power supply socket must be connected to the earth line to ensure the safety.

The power of A48 lighting console has steady voltage output in so wide range of power supply voltage that it is adapted to the power supply of different countries. Before the power supply is connected, please check whether the voltage is in normal range of A48 to ensure the safety.

Power fuse

When fuse needs to be replaced, please use one with same current capacity signed on the rear.

Audio signal input

There are a 1/4" mono audio socket and an internal microphone in A48 lighting console. When audio input line is plugged into audio socket, rhythm of input music is used as trigger signal of chase program. When audio input line is pulled out from audio socket, rhythm of environment sound picked up by internal microphone is used as trigger signal of chase program.

DMX signal output

There is a XLR-3 output socket on the rear of A48. Please connect plug of DMX as following:

Foot of socket/plug	Illustration
1	Earth line of DMX
2	Signal -
3	Signal +

DMX512 signal cable

According to DMX512 protocol, DMX signal cable must be screened twist cable with impedance of 120Ω . The length of cable should not be over 250m. PIN 2 and PIN 3 of the plug cannot be confused, please distinguish two lines of twist cable by different colors.

Connection of DMX512 signal

The connection between DMX512 signal and other equipment is a "chrysanthemum chain" mode. DMX512 signal is sent from A48 lighting console output to DMX512 input of the first dimmer. Then it is sent from DMX512 output of the first dimmer to DMX512 input of the second dimmer and goes on like this.

An 120Ω terminal matching resistance must be connected to the last equipment to prevent reflection and aberration of signal. The operation is as following: connect a 120Ω resistance to foot 2 and foot 3 of a plug then plug it to the output of the last scanner equipment.

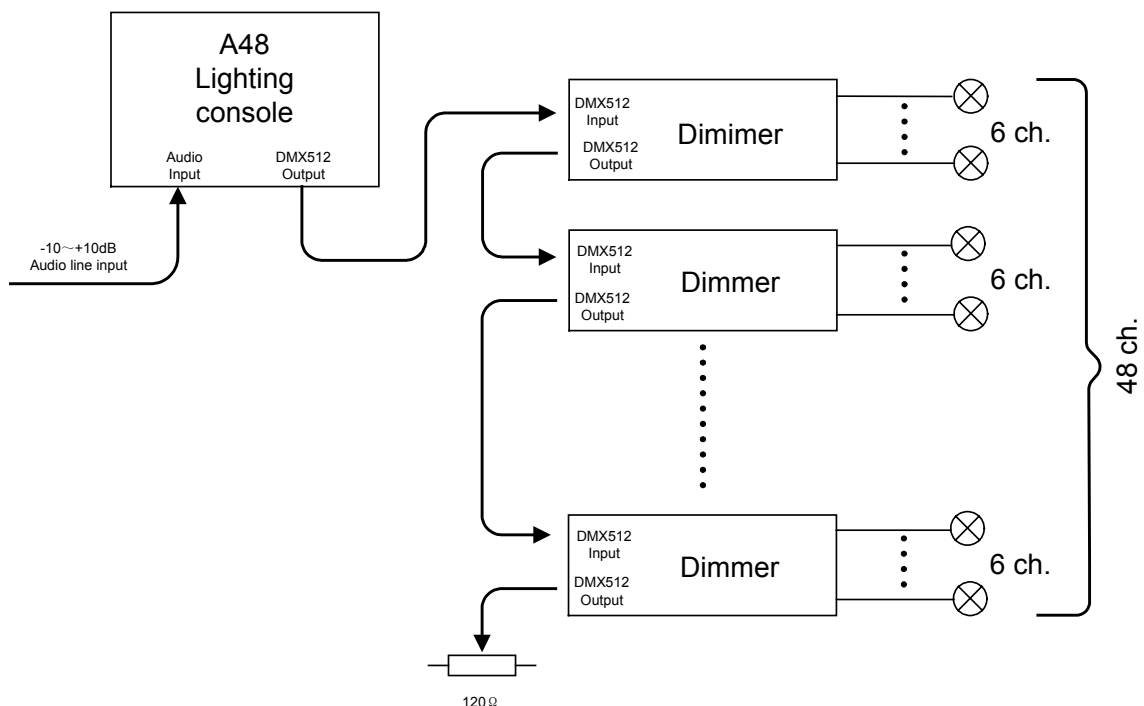

Address distribution of DMX512

A48 lighting console uses 1-48 channels dimmer of DMX512 protocol. If eight 6-channel dimmers are connected, the receiving address setting as follow: 1, 7, 13, 19, 25, 31, 37, 43.

Running section

Manual control

1. Push the master slider to the maximum.
2. Use the channel master slider to adjust brightness ratio.
3. Use 25-48 key to switch channel from 1-24 to 25-48.
4. Adjust the brightness of different channel.
5. Clear the channel value of CH1-CH48 quickly: Press and hold down the "Enter" key, followed by button the "Delete" key.

Submaster control

Each submaster can control 1 scene of brightness ratio. Push up the corresponding submaster slider will output this scene. Use the page key to control the scene 1~12, 13~24, 25~36. A48 can outputs 12 scenes synchronously.

The display mode for submaster slider: When the slider is pushed up, the corresponding LED will change the brightness followed by the location of slider. When the LED flashes, it indicates this slider to be managed by other page. The sliders controlled by current page can be checked using the submaster page key.

The brightness of corresponding submaster 's LED(not flash) indicates the level of submaster's output in current page. When changing to the other page, the submaster 's LED will flashes to prompt these sliders located in the previous page. If the slider is push down to zero location, this submaster slider's LED will indicates the output followed by this slider.

Running chase

1. Adjust Chase output to the maximum。
2. Use the direction key to select chase number.
3. Press the "Enter" key to confirm.
4. Use the Speed slider to adjust the chase's speed.
5. Use the Cross slider to change the effect of gradual change.
6. To change the direction of the Chase: Press and hold down the "Enter" key, followed by button the direction key to change the direction of the Chase.
7. When press the "Music" key, the LED is on, the Chase is triggered by the rhythm of music. If the audio signal is connected, the Chase will be triggered by input audio signal. Otherwise the Chase is triggered by the internal microphone of A48.

Edit section

Submaster edit

1. Adjust the Master slider and Channel master slider to maximum.
2. Adjust brightness value of each Channel according to the manual mode. This will make of a Scene.
3. Press "Save to Sub" key, the LED will flashes.
4. Use the submaster page key to select the target page.
5. Press the corresponding number key to save this Scene.

Modify Submaster

To edit a existed submaster, use the following mode:

1. Push up the slider which is modified, the Channel's LED will indicates the relevant brightness value of Channel.
2. Press the "Save to Sub" key, the LED flashes. Use the Channel slider to modify the brightness of each channel respectively.
3. Once this operation is finished, press the key under the slider to store the result.

Chase edit

1. By holding the "Edit" key down for 2 seconds until the LED flashes. This will enter the program state.
2. Use the right and left key to select the Chase number, press "Enter" key to confirm.
3. Use the right and left key to select the step number of Chase. If the current step number is the same as the total step number, it indicates the current step is the last step. Press the right key to add a new step.
4. Adjust Channel slider or use the submaster scene directly to set brightness of each Channel.
5. Repeat point 3~4 to set the brightness value of next step of Chase.
6. The effect of light can be checked by using direction key momentarily in programming process.
7. Repeat point 2~6 to edit the other Chase.
8. Press the "Edit" key for 2 seconds to exit the program state.

MEMO