



AF-3/AF-3X/AF-3S
Special Effects Fan
User Manual
- English
- 中文



© 2023 Antari Lighting and Effects Ltd.

1. Introduction.....	1
2. Safety Information	1
3. Package Contents & Inspection	2
4. Machine Details	2
5. Technical Label Information	3
6. Machine Variation	4
7. Setting and Manual Operation	4
8. Control Settings	4
9. DMX Connection.....	4
10. Z-3 Cable Remote (Optional)	6
11. WTR-10 Wireless Remote (Optional).....	6
12. Service and Maintenance	7
13. Technical Specifications	8
14. Warranty Disclaimer	8
15. Machine Dimension	8
1. 前言.....	9
2. 安全注意事項.....	9
3. 包裝內容與檢查.....	10
4. 機器訊息.....	11
5. 技術標籤資訊.....	12
6. 機型比較.....	12
7. 設定與手動操作說明.....	12
8. 控制設定.....	13
9. DMX 說明	13
10. Z-3 有線控制器(選配).....	14
11. WTR-10 無線控制器(選配).....	14
12. 維護和保養.....	15
13. 技術規格.....	16
14. 保固聲明.....	16
15. 機器尺寸圖.....	16
Appendix I - Grounding Instruction	17





User Manual

1. Introduction

Please read all the user manual before operating the machine, and place the manual where the user can refer to it at all time. The manual includes how to install and operate the machine under safe condition and explain all the labels printed on the machine. If you encounter any problem, contact your local Antari dealer for assistant immediately.

2. Safety Information

 DANGER	If the danger is not avoided, it will cause death or serious injury
 WARNING	If the warning is not heeded, it can cause death or serious injury.
 CAUTION	If the precaution is not taken, it may cause minor or moderate injury.



DANGER

- Must connect the machine to the correct rated voltage or it might lead to an electrical shock or a burn and may cause serious consequences.
- Must connect the machine to a protected circuit and ensure it is properly grounded to avoid the risk of electrocution. For grounding instruction, please refer to Appendix I on page 17.
- Do not operate the machine with a bundled power cord, it could lead to a fire hazard.
- Do not use the fan in an environment full of flammable gas, susceptible to water or powder. Keep away from any fire and heat sources.
- When operating the machine, do not point at people, animals, or fire.



WARNING

- Please operate the machine on a flat, level hard and well ventilated surface area, reserve at least 50cm space around the machine and make sure there is no flammable gas or material nearby.
- Do not disassemble, repair or modify the machine, it may cause damages, malfunction, risk of electrical shock or result in fire.
- The machine can only be operated by adults or professionals, is not intended for use by person with reduced physical sensory, mental capabilities, or lack of experience and knowledge including children.
- Do not leave the machine running unattended, make sure all powers are off when leaving.
- Children should be supervised to ensure that they do not play with the machine.
- Do not use the machine upside down or tilt it, it might cause damages or malfunction.
- Never allow any object or part of your body to enter path of the fan blades to prevent any injury or damages
- Do not spray the fan with any liquid including cleaner and insecticide to avoid injury or damages.



CAUTION

- Keep the machine dry at all time. The machine is not waterproof, do not expose the machine to water, rain, or moisture environment.
- Please make sure the power outlet is not damaged or loose before plug in the power cord.
- If the power cord is damaged, it must be replaced by Antari or its local dealers, otherwise the warranty will be void.
- The machine is for indoor use only.
- Do not operate the machine in any area with unstable voltage.
- If you experience strange sound or malfunction, turn off the power and unplug the power cord immediately and contact your local Antari dealer for assistant.
- Do not contact any moving part.

- Only use accessories recommended or sold by Antari.
- Please make sure the power is off when not using the machine and unplug the power cord if not intend to use for a long period of time.
- To disconnect, turn all controls to the off position, then remove plug from outlet.
- Do not unplug by pulling on cord. To unplug, grasp the plug, not the cord.
- Unplug from outlet before servicing or cleaning.
- Ensure that curtain, clothing, cables or other items cannot be suck into the fan.
- Do not operate the machine with a damaged cord or plug, or after the machine malfunctions or is dropped or damaged in any manner. Return machine to the nearest authorized service facility for examination, repair, or electrical or mechanical adjustment.
- After a period of operation, abnormal noise and uneven air volume may appear because of dust blocking airflow. It will disappear after cleaning the air inlet and outlet.

Before operating the machine, please read all warning labels on the machine, description as below:

WARNING!

1. Do not allow any object or part of your body get near the protection grill while operating the fan.
2. Operate fan only with adult supervision.
3. Do not use fan without protection grill.
4. Do not use the fan in damp environment.

3. Package Contents & Inspection

Immediately upon receiving the machine, carefully unpack the carton, check the content to ensure it is the correct model and all parts are included. If any part appears to be damaged or missing during transportation, please contact your local dealer and return with original package for inspection.

3.1 Package Contents

AF-3 Compact Effects Fan	AF-3X Compact Effects Fan	AF-3S Compact Effects Fan
1 x AF-3 Compact Effects Fan	1 x AF-3X Compact Effects Fan	1 x AF-3S Effects Fan
1 x Neutrik powerCon Cable Connector		
1 x User Manual or Scan QR Code on the Machine		

3.2 Optional Accessories

Item Code	Description
Z-3	Cable Remote
WTR-10	Wireless Remote (W-1 Transmitter/W-1 Receiver)

4. Machine Details

AF-3

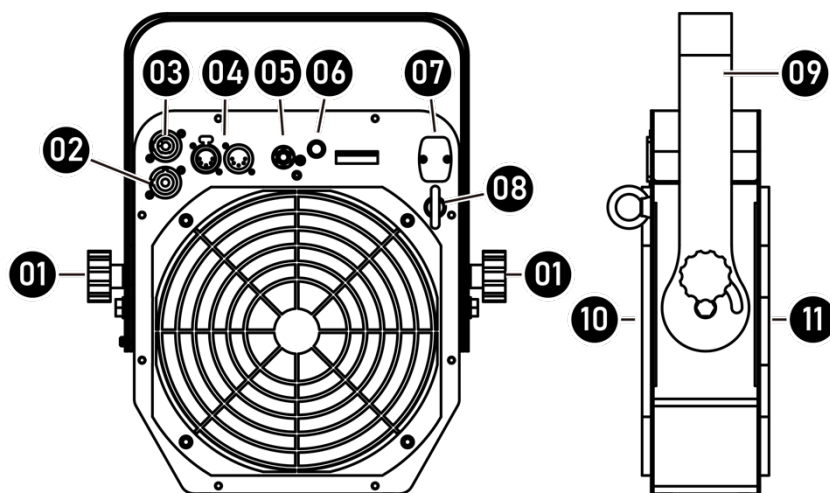

01. Adjusting Knob	07. Wireless Connector
02. Neutrik powerCon Cable Connector IN	08. Ring
03. Neutrik powerCon Cable Connector OUT	09. Bracket
04. XLR 5-Pin DMX	10. Air Inlet
05. Cable Remote Connector	11. Air Outlet
06. Rotary Knob	

AF-3X

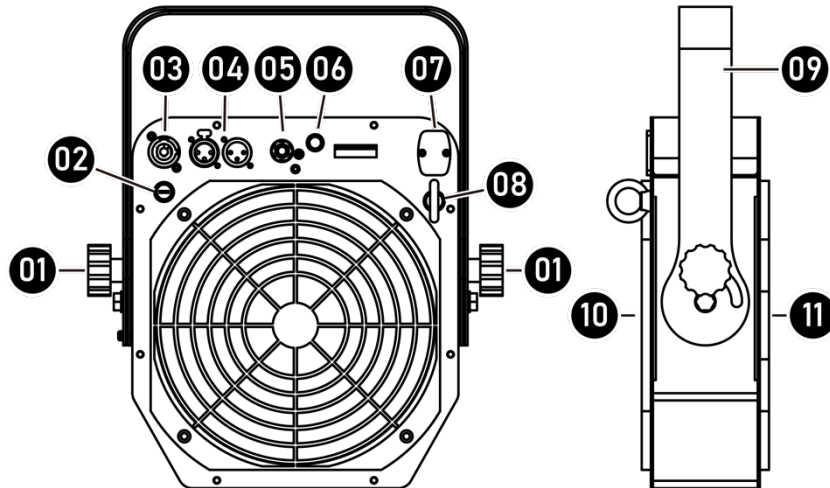

01. Adjust Knob	07. Wireless Connector
02. Fuse	08. Ring
03. Neutrik powerCon Cable Connector	09. Bracket
04. XLR 5-Pin DMX	10. Air Inlet
05. Cable Remote Connector	11. Air Outlet
06. Rotary Knob	

AF-3S

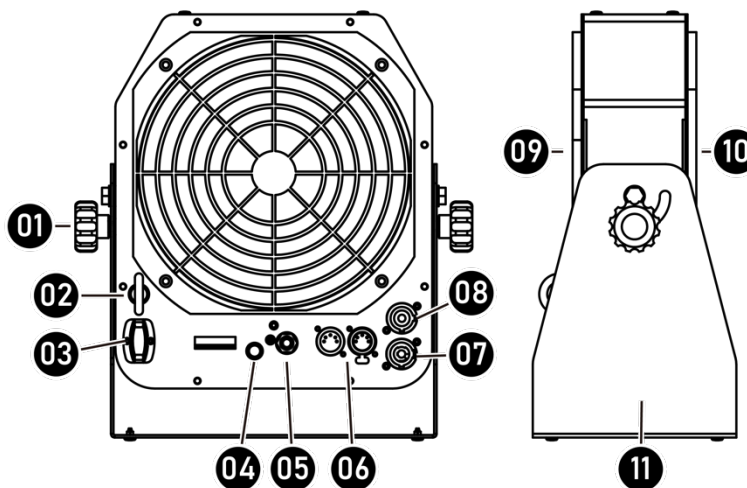

01. Adjusting Knob	07. Neutrik powerCon Cable Connector IN
02. Ring	08. Neutrik powerCon Cable Connector OUT
03. Wireless Connector	09. Air Inlet
04. Rotary Knob	10. Air Outlet
05. Cable Remote Connector	11. Bracket
06. XLR 5-Pin DMX	

5. Technical Label Information

Please read the technical label information on the back of the machine before operating it.

1. Model Name	5. Breaker / Fuse
2. Input Voltage	6. QR CODE for User Manual
3. Frequency	7. Serial No.
4. Rated Power	

6. Machine Variation

AF-3	AF-3X	AF-3S
Series Power Supply Available	Series Power Supply Unavailable	Design for CH-1 with Flight Case

7. Setting and Manual Operation

- Step 1.** Place the machine on a flat, level hard and well ventilated surface area and reserve at least 50cm open space around the machine, and make sure there is no flammable gas or material nearby;
- Step 2.** Plug the machine to the power outlet. Please read the technical label on the back of the machine and make sure the power outlet has the correct rated voltage for the machine;
- Step 3.** Turn on the power, when the status indicator display green indicates the fan is in standby status and ready for operation;
- Step 4.** To start, turn the rotary knob to the right to increase fan speed and to the left to decrease the fan speed, to stop turn the rotary knob to minimum (-), when fan is in operation the indicator light show orange;
- Step 5.** To turn off the power, please make sure the machine is not operating. If you will not use the machine a long period of time, please unplug the power cord.

8. Control Settings

AF-3 Series Compact Effects Fan can be operated in the following modes. The machine can only accept 1 type of signal at a time. When using different control modes at the same time, the machine will work according to built-in control priority:

- Manual
- DMX512
- Wireless
- Cable Remote

9. DMX Connection

9.1 DMX Connector Pin Assignment

The machine has a XLR 5-Pin for DMX connection. The diagram below indicates pin assignment information.



5 Pin XLR

Pin	Function
1	Ground
2	Data-
3	Data+
4	N/A
5	N/A

** There is a protection cap on DMX IN, please remove it with your finger before operation.

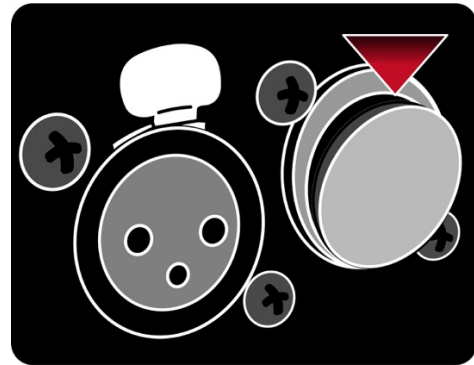

9.2 DMX Setting

DMX Value	Function
0~5	Fan off
6~254	Speed up linearly
255	Maximum speed

9.3 Addressing

Each device occupies 1 channel. To ensure that the control signals are properly directed to each device, they require addressing. This is to be adjusted for every single device by changing the DIP-switches as set out in the table below. The starting address is defined as the first channel from which the device will respond to the controller. Please make sure that you do not have any overlapping channels in order to control each device correctly and independently from any other fixture on the DMX data link. If two, three or more devices are addressed similarly, they will work similarly.

Occupation of the DIP-Switches:

DIP	1	2	3	4	5	6	7	8	9	10
Ch.	1	2	4	8	16	32	64	128	256	Wireless pairing, control on/off

SW.	11	12
ON	2 CH Mode	Wireless Pairing
OFF	1 CH Mode	No Function

Device Number & Channels	Starting Address	1	2	4	8	16	32	64	128	256
Device 1 – Channel 1	On	▲								
	Off		▽	▽	▽	▽	▽	▽	▽	▽
Device 2 – Channel 2	On		▲							
	Off	▽		▽	▽	▽	▽	▽	▽	▽
Device 3 – Channel 3	On	▲	▲							
	Off			▽	▽	▽	▽	▽	▽	▽
Device 4 – Channel 4	On			▲						
	Off	▽	▽		▽	▽	▽	▽	▽	▽
Device 5 – Channel 5	On	▲		▲						
	Off		▽		▽	▽	▽	▽	▽	▽

10. Z-3 Cable Remote (Optional)



Z-3 Cable Remote is an optional accessory for AF-3/AF-3X Special Effects Fan, please see instruction below;

1. Plug the cable remote to the connector on the back of the machine;
2. Press the red button to turn the power of the remote on, red indicator light is solid;
3. You can start to turn the knob to activate the fan and adjust the fan speed.

** If you encounter any problem, please contact your local Antari dealer for assistant

11. WTR-10 Wireless Remote (Optional)

WTR-10 Wireless Remote is an optional accessory for AF-3/AF-3X Special Effects Fan, it included a W-1 wireless transmitter and a W-1 wireless receiver. If you already purchased the wireless model, it's ready to use. If you purchase the WTR-10 Wireless Remote afterwards, please follow the instruction below. If you encounter any problem, please contact your local Antari dealer for assistant.

11.1 W-1 Wireless Transmitter & Receiver

- Battery : 27A 12V
- Effective Range : The effective range is approximately 50m, depends on actual condition, it may vary.
- W-1 wireless transmitter has 2 buttons, each function as follow:

Button	Function
[A]	Start Fan
[B]	Stop Fan



W-1 Wireless Transmitter

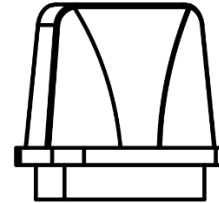

W-1 Wireless Receiver

11.2 W-1 Wireless Receiver Installation

If you purchased the WTR-10 Wireless Remote afterwards, please follow the instructions below to install the receiver. If you encounter any problem, please contact your local Antari dealer for assistant.

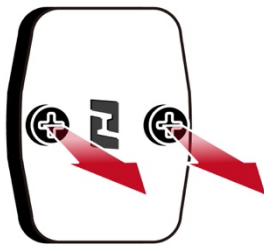

Graph 1

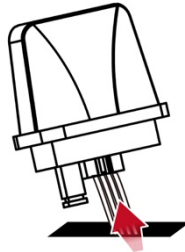

Graph 2



Graph 3

1. Please see graph 1, remove the cover from the pointed place;
2. You will see a white cable like graph 2, pull it out and connect to the W-1 receiver;
3. Screw it back to the machine like graph 3 and follow the instruction on 11.3 for pairing.

11.3 Pair & Unpair

Each receiver can pair up to 5 transmitters, please follow the steps below to pair or unpair the remote;

- Step 1.** Set DIP switch No.10 to “ON” position;
- Step 2.** Status will show red light for 10 seconds, press “A” or “B” on the transmitter to pair it; status indicator will show green light if pair is successful;
- Step 3.** If you want to pair extra transmitter, turn DIP switch No.10 to “OFF” position first and repeat Step 2.;
- Step 4.** To unpair, set DIP switch No.10 to “OFF” position;

12. Service and Maintenance

	DANGER!	Disconnect the power cord before starting maintenance operation!
---	----------------	--

- Always keep the machine clean.
- Can use an air compressor, a vacuum or a soft brush to remove the dust on the machine.
- Can use a slightly damp cloth to clean the casing.
- It is recommended to run the machine at least once a month in order to maintain its best performance and output condition.
- Excessive dust will reduce the performance and cause overheat.

13. Technical Specifications

	AF-3/AF-3X	AF-3S
Rated Voltage	US Model : AC 100-120V, 50/60Hz 1.5A EU Model : AC 220-240V, 50/60Hz 1.0A	
Rated Power	127W	
Ambient Temp. Range	0°C - 40°C (32°F - 104°F)	
Air Flow	530 CFM (50Hz) 、 600 CFM (60Hz)	
Fan Speed	750 - 2550 rpm (50Hz) 、 750 - 2800 rpm (60Hz)	
Noise Level	72.6 dB (Max. Output)	
Control Methods	Manual 、 DMX512 、 Wireless (Optional) 、 Cable Remote (Optional)	
Interface	XLR 5-Pin (DMX) 、 Neutrik powerCon (Power)	
DMX Channel	1 Channel	
Included Accessories	N/A	
Optional Accessories	Z-3 Cable Remote 、 WTR-10 Wireless Remote	
Dimension	L 124 W 316 H 368 mm (L 4.88 W 12.44 H 14.49 inch)	L 160 W 312 H 336 mm (L 6.29 W 12.28 H 13.24 inch)
Weight	6.0 kg (13.23 lbs.)	6.4 kg (14.00 lbs.)

14. Warranty Disclaimer

We guarantee the merchandise manufactured by us to be free from defect in material and workmanship for a period of one year. Our obligation and liability under this warranty shall be restricted to repair or replacement at our factory or local authorized dealer. We assume no liability of the products that are improperly used or used for any purpose other than that for which they are specially designed. This warranty shall not apply to any merchandise which has been repaired, altered or assembled outside our factory in any way so as in our judgment to affect its performance, nor which has been subjected to misuse, negligence, or accident nor to any merchandise operated contrary to our printed instructions. We will not allow or be liable of any loss or any damages of any kind in connection with the use, sale, or repair of any merchandise purchased from us.

15. Machine Dimension

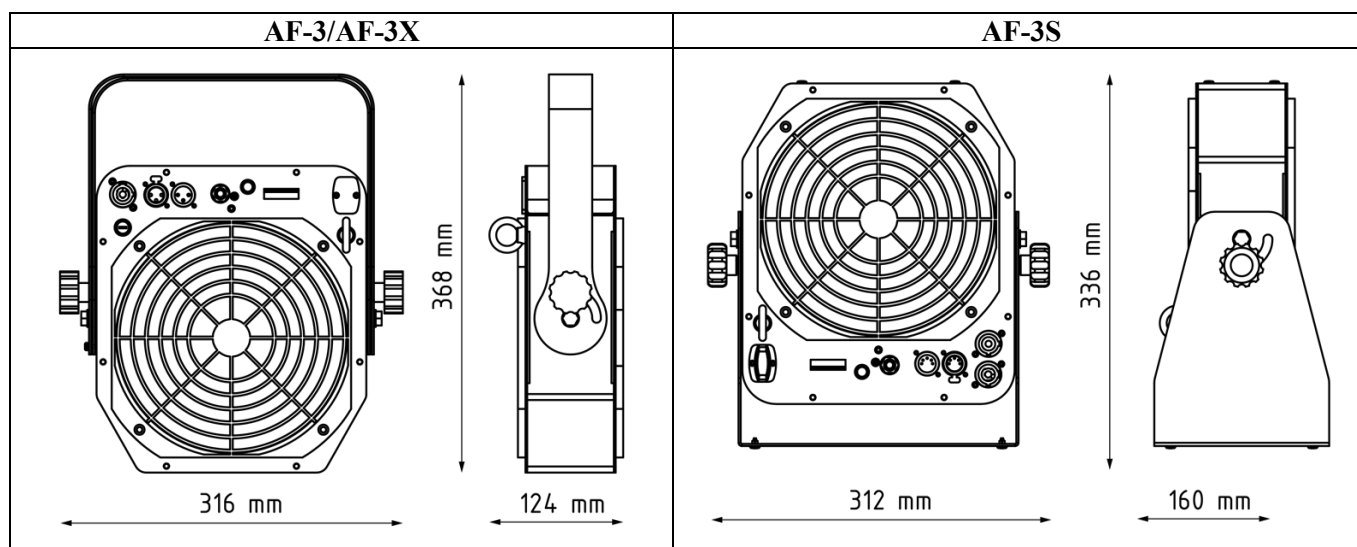





中文使用說明書

1. 前言

在操作本機器之前，請務必仔細詳閱本說明書然後請將本說明書放置在機器使用者可隨時查閱之處存放。此說明書包含如何安全的安裝及操作本機器以及說明所有在機器上的標示。如果您有任何操作上的問題，請立即聯繫當地的 Antari 經銷商尋求協助。

2. 安全注意事項

 危險	若不確實避免這些指示，可能導致嚴重人身傷害甚至死亡。
 警告	若不確實遵循這些指示，可能導致嚴重人身傷害甚至死亡。
 注意	若不確實注意這些指示，可能導致人身傷害甚至死亡，嚴重程度視情況而定。

危險

- 請務必使用正確電壓。如果使用錯誤電壓，可能會遭受危險的電擊燒傷或更嚴重的後果。
- 請務必將機器連結到有保護的電路，並確保有正確地接地，以避免觸電的危險。關於接地方式請參考第 17 頁附錄 I。
- 請勿在捆綁電源線的情況下使用，可能會發熱導致火災。
- 禁止在有易燃氣體、易被水淋、粉塵較多的地方使用風扇。請遠離火源及熱源。
- 操作機器時請勿將機器對著人體、動物或火焰使用。

警告

- 請於堅固、平坦、穩定且通風良好的表面上使用機器。請勿遮蓋機器散熱部份，機器周邊至少應保留公分的空間並確認附近沒有易燃性物質或可揮發性氣體。
- 請勿隨意拆卸、修理或改造機器，這可能會導致機器故障、損壞、觸電危險或造成火災。
- 本機器僅限有行為能力之成人或專業人員操作，不預期提供生理、感知、心智能力、經驗或知識不足者之使用者(包含孩童)使用本機器。
- 請勿在無人看管時讓機器運作，並於外出離去時確實關閉電源。
- 孩童應受監督，以確保孩童不能操作或嬉戲玩本機器。
- 請勿將機器倒放或傾斜使用，可能導致機器動作不正常或損壞。
- 禁止將其他物體或身體部位插入前後網內，避免受傷或損壞。
- 請勿將任何液體包含清潔劑與殺蟲劑等，噴向風扇避免受傷或損壞。

注意

- 本機器無防水設計，請隨時保持機器乾燥、嚴禁將其潑水、浸水、淋雨或放在潮溼的環境。
- 在插入電源插座前，請確認電源插座無損壞或鬆動。
- 若電源線損壞，必須使用原廠電源線或組件進行更換，否則將導致保固無效。
- 本產品僅限室內使用。

- 請勿在電壓不穩定的地區使用本機器。
- 如果機器出現異常聲音或有任何不正常現象時，請立即停止工作，將電源關閉及拔下機器電源線，並請聯繫當地的 Antari 經銷商尋求協助。
- 請勿觸碰機器內部運轉零件。
- 只能使用原廠建議或販售之配件。
- 請確認機器不在使用的狀態下電源已關。如果長時間不使用機器，請拔掉電源線。
- 關閉機器時，將所以控制開關轉到關閉的位置，然後再將插頭從插座拔除。
- 拔除電源線時，請抓住插頭不是電線。
- 應遠離窗簾、衣物、電線或其他異物，避免被風扇葉片捲入。
- 在保養及清潔前，請把電源線從插座拔除。
- 在電線或插座有損毀、機器故障或有掉落或損壞的情形發生時，請勿操作機器。請將機器送回最近的維修站，做檢查、維修及電源或機械的調整。
- 使用一段時間後，因為灰塵阻擋空氣流動，有可能會產生異音或不均勻風量。在清潔過後就會恢復正常。

在使用本機之前，請詳細閱讀機器上的警語標示，說明如下：

WARNING! 警告!

1. Do not allow any object or part of your body get near the protection grill while operating the fan. 使用風扇時，禁止將其他物體或身體部位靠近保護網內
2. Operate fan only with adult supervision. 僅在成人監督下使用風扇
3. Do not use fan without protection grill. 請勿在無保護網時使用風扇
4. Do not use the fan in damp environment. 請勿在潮濕環境使用風扇

3. 包裝內容與檢查

在收到機器後，請立即小心地打開包裝紙箱，檢查所有內容，確認您所購買的機型及配件。如果有任何部件因運輸過程出現損壞或缺少，請立即連絡經銷商，並以原包裝退回檢查。

3.1 包裝內容

AF-3 特效風扇	AF-3X 特效風扇	AF-3S 特效風扇
1 x AF-3 特效風扇	1 x AF-3X 特效風扇	1 x AF-3S 特效風扇
1 x Neutrik powerCon 電源線		
1 x 說明書或掃描機身 QR Code		

3.2 選配說明

品項	描述
Z-3	有線控制器
WTR-10	無線控制器(W-1 無線發射器/W-1 無線接收器)

4. 機器訊息

AF-3

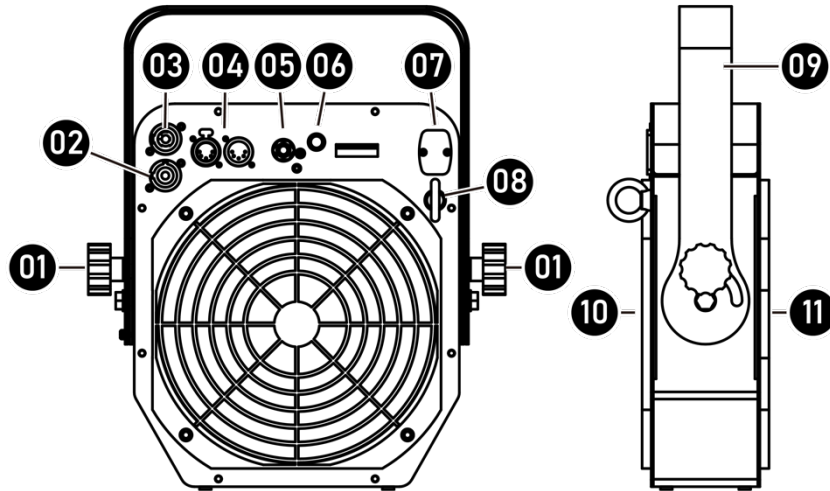

01. 調整旋鈕	07. 無線控制器接頭
02. Neutrik powerCon 電源線連接頭 OUT	08. 吊環
03. Neutrik powerCon 電源線連接頭 IN	09. 支架
04. XLR 5-PIN DMX 連接頭	10. 入風口
05. 有線控制器接頭	11. 出風口
06. 控制旋鈕	

AF-3X

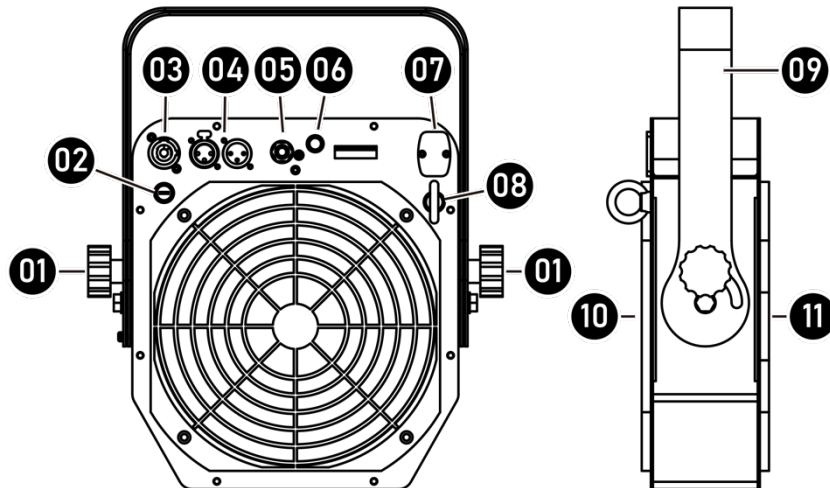

01. 調整旋鈕	07. 無線控制器接頭
02. 保險絲	08. 吊環
03. Neutrik powerCon 電源線連接頭	09. 支架
04. XLR 5-PIN DMX 連接頭	10. 入風口
05. 有線控制器連接頭	11. 出風口
06. 控制旋鈕	

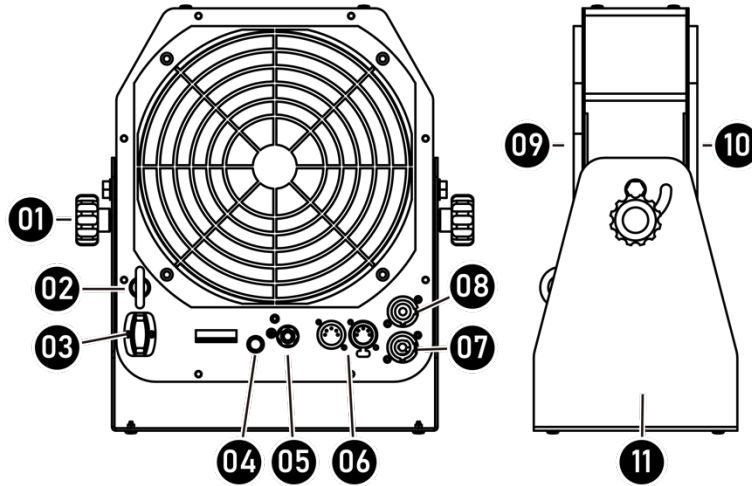

01. 調整旋鈕	07. Neutrik powerCon 電源線連接頭 IN
02. 吊環	08. Neutrik powerCon 電源線連接頭 OUT
03. 無線控制器連接頭	09. 入風口
04. 控制旋鈕	10. 出風口
05. 有線控制器連接頭	11. 底座
06. XLR 5-PIN DMX 連接頭	

5. 技術標籤資訊

使用本機器前，請詳閱位於機器後方的技術標籤訊息。

1. 機器型號	5. 保險絲規格
2. 工作電壓	6. 說明書 QR CODE
3. 頻率	7. 機器流水序號
4. 瓦特數	

6. 機型比較

AF-3	AF-3X	AF-3S
電源可串聯	電源不可串聯	只能 CH-1 機器使用

7. 設定與手動操作說明

- 步驟1.** 將機器平放在堅固、平坦、穩定且通風良好的表面上，機器周圍至少應保留 50 公分的空間並確認附近沒有易燃性物質或可揮發性氣體；
- 步驟2.** 將機器連接電源插座，連接之前，確認機器背後技術標籤上所標示要求功率，是否與電源插座相符；
- 步驟3.** 啟動機器電源後，狀態燈號顯示綠燈，代表機器在待機模式並可以進行操作。
- 步驟4.** 欲開始，將控制旋鈕轉向右邊增加風扇速度轉向右邊降低風扇速度；欲停止，將控制旋鈕轉到 (-) 位置；風扇運作時狀態燈號顯示橘燈；
- 步驟5.** 需關閉機器時，請確認機器已停止運轉，再將電源關閉即可，長時間不使用時請拔除電源線。

8. 控制設定

AF-3/AF-3X 特效風扇可以使用下列操作模式，機器每次接受一種訊號。當同時間使用多種訊號時機器將根據原廠內建訊號的優先順序來進行工作；

- 手動控制
- DMX512
- 無線控制
- 有線控制

9. DMX 說明

9.1 DMX 說明

本機可提供一個 XLR 5-PIN 的 DMX 連接頭選擇。下為 PIN 的接點說明：



5 Pin XLR

Pin	功能
1	接地
2	數據-
3	數據+
4	N/A
5	N/A

DMX IN 連接頭上的蓋子是一個保護蓋，操作前，請用手指撥開即可輕鬆地將其取下。

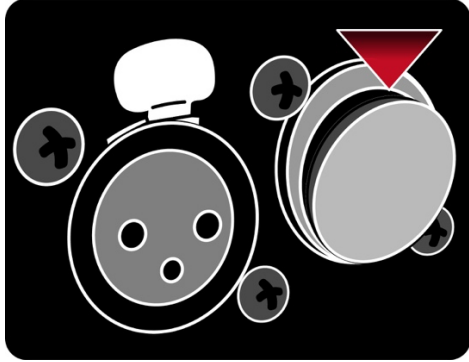

9.2 DMX 通道功能設定

DMX 數值範圍	功能
0~5	風扇關閉
6~254	增加風扇速度
255	最高風速

9.3 DMX 地址說明

每台機器會佔據一個通道。他們都需要一個地址來確保控制訊號是正確指向每台機器。請按照下圖，使用前，必須針對每一台機器透過指撥開關來調整。起始地址是定義為機器響應控制器的第一個通道。請確保你沒有任何重複的通道才能夠正確及獨立的透過 DMX 數據鏈結來操控每台機器。如果二、三或多台機器有類似的地址他們將運作相似。

指撥開關控制說明：

DIP	1	2	3	4	5	6	7	8	9	10
Ch.	1	2	4	8	16	32	64	128	256	Wireless pairing, control on/off

SW.	11	12
ON	2 CH Mode	Wireless Pairing
OFF	1 CH Mode	No Function

Setting the DMX-Starting Address	DIP-Switch No.	1	2	3	4	5	6	7	8	9
Device Number & Channels	Starting Address	1	2	4	8	16	32	64	128	256
Device 1 – Channel 1	On	▲								
	Off		▽	▽	▽	▽	▽	▽	▽	▽
Device 2 – Channel 2	On		▲							
	Off	▽		▽	▽	▽	▽	▽	▽	▽
Device 3 – Channel 3	On	▲	▲							
	Off			▽	▽	▽	▽	▽	▽	▽
Device 4 – Channel 4	On			▲						
	Off	▽	▽		▽	▽	▽	▽	▽	▽
Device 5 – Channel 5	On	▲		▲						
	Off		▽		▽	▽	▽	▽	▽	▽

10. Z-3 有線控制器(選配)



Z-3 有線控制器是 AF-3/AF-3X 特效風扇的選購配件，使用方法如下；

1. 將有線控制器插入機器後方的接頭；
2. 按下紅色按鈕開啟電源，紅色指示燈亮起靜止不動；
3. 旋轉旋鈕啟動風扇並調整風扇速度。

**如果有任何問題，請聯繫當地的 Antari 經銷商尋求協助。

11. WTR-10 無線控制器(選配)

WTR-10 無線控制器組包含一個 W-1 無線發射器及 W-1 無線接收器，此為 AF-3/AF-3X 特效風扇的選購配件。若您採購的版本已含無線功能即已安裝至機器上，可直接使用。若是後續採購 WTR-10 無線控制器，請按照下方說明進行安裝與配對。如果遇到任何困難與問題，請與當地的 Antari 經銷商尋求協助。

11.1 W-1 無線發射器&接收器說明

- 發射器：使用 27A 12V 電池
- 收發距離：有效距離為 50 公尺，實際收訊狀況根據現場環境因素而有所不同。
- W-1 無線發射器配有 2 個按鈕，控制功能為：

按鈕	功能
[A] 鍵	啟動風扇
[B] 鍵	停止風扇



W-1 無線發射器

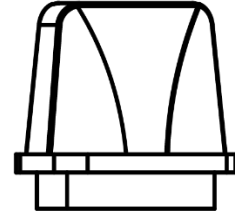

W-1 無線接收器

11.2 W-1 無線接收器安裝說明

如果是後續採購 WTR-10 無線控制器，請按照下方說明進行安裝與配對。如果遇到任何困難與問題，請與當地的 Antari 經銷商尋求協助。

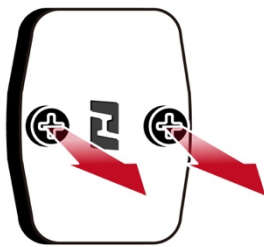

Graph 1

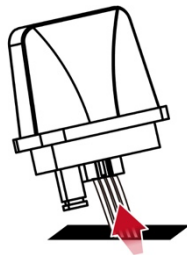

Graph 2



Graph 3

1. 請看圖一，取下蓋子;
2. 請看圖二，取下後，你會看到一條白色的線，請拉出來接在 W-2 接收器上;
3. 請看圖三，將接收器鎖回去原本的地方，然後按照 11.3 的步驟開始配對。

11.3 配對 & 取消配對

每個接收器可以配對最多 5 個控制器，請參考下面步驟配對和取消配對控制器;

步驟 1：將指撥開關 10 號撥到"ON"的位置;

步驟 2：狀態燈號會紅燈閃爍 10 秒，此時按下無線遙控器上的"A"或"B"即可配對，配對成功後狀態燈號將會顯示綠燈;

步驟 3：如果要配對多個無線發射器，請將撥指開關 10 號撥到"OFF"的位置，然後重複步驟 2 即可。

步驟 4：欲解除配對，將撥指開關 10 號撥到"OFF"的位置。

12. 維護和保養



危險!

維修保養之前，請務必拔除電源線！

- 隨時保持機器清潔。
- 可以使用空氣壓縮機、吸塵器或軟刷除去機器上的灰塵。
- 機殼可使用濕布擦拭。

- 建議每月至少讓機器運轉一次，以保持機器處於最佳的性能和輸出條件。
- 機器上過多的灰塵會降低機器工作性能，導致散熱不良。

13. 技術規格

	AF-3/AF-3X	AF-3S
額定電壓	美規：AC 100-120V, 50/60Hz 1.5A 歐規：AC 220-240V, 50/60Hz 1.0A	
額定功率	127 瓦	
適用環境溫度	0°C – 40°C (32°F – 104°F)	
風量	530 立方英尺/分 (50 赫茲)、600 立方英尺/分(60 赫茲)	
風扇速度	750-2550 轉(50 赫茲)、750-2800 轉(60 赫茲)	
噪音值	72.6 分貝(最大輸出)	
控制方式	手動控制、DMX512、無線控制(選配)、有線控制(選配)	
連接座	XLR 5-PIN(DMX)、Neutrik powerCon(主電源)	
DMX512 通道	1 個頻道	
隨附配件	無	
選購配件	Z-3 有線控制器、WTR-10 無線控制器	
尺寸	長 124 寬 316 高 368 公釐 (長 4.88 寬 12.44 高 14.49 英寸)	長 160 寬 312 高 336 公釐 (長 6.29 寬 12.28 高 13.24 英寸)
重量	6.0 公斤 (13.23 磅)	6.4 公斤 (14.00 磅)

14. 保固聲明

本公司保證我們的商品在一年內沒有材料和製作缺陷。我們在本保證下的義務和責任僅限於在原廠或當地授權經銷商進行的維修或更換。我們對不當使用或用於非專門設計目的以外之用途不承擔任何責任。本保固不適用於以任何方式在原廠或當地授權經銷商外修理、改動或組裝的任何商品，以便我們判斷影響其性能，沒有受到誤用、疏忽或事故的影響，也沒有違反我們的任何商品操作印刷說明。本公司對於從我們這邊購買的商品不會允許也不對於使用、銷售或修理任何產品有關的任何類型的任何損失或損害承擔責任。

15. 機器尺寸圖

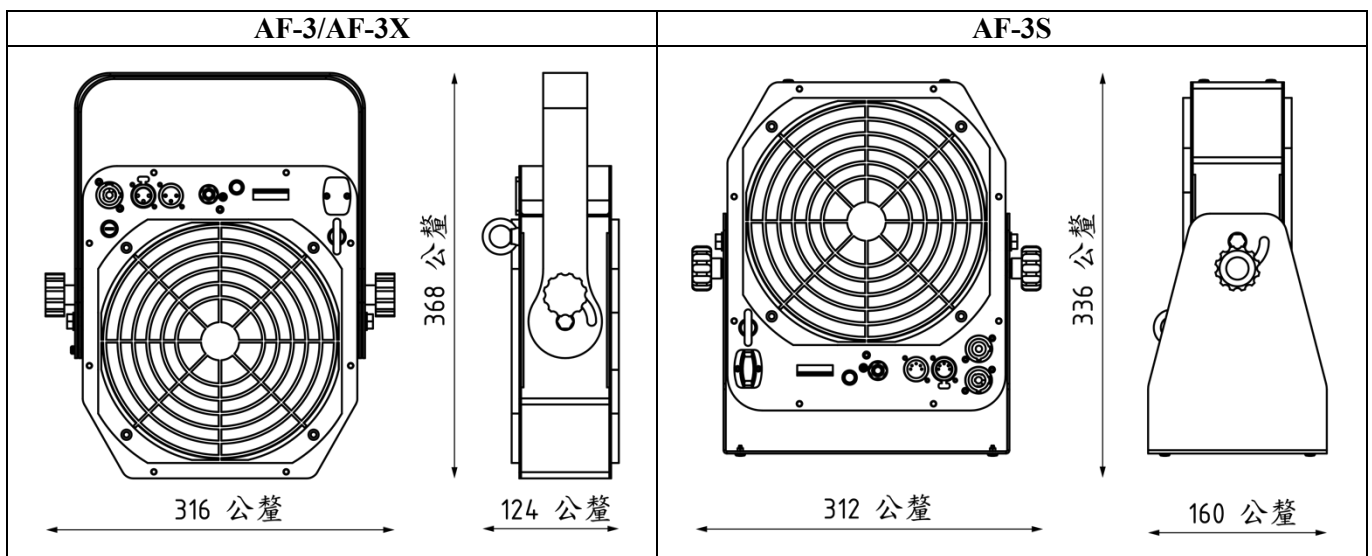

Appendix I - Grounding Instruction

This appliance must be grounded. In the event of malfunction or breakdown, grounding provides a path of least resistance for electric current to reduce the risk of electric shock. This appliance is equipped with a cord having an equipment-grounding conductor and a grounding plug. The plug must be plugged into an appropriate outlet that is properly installed and grounded in accordance with all local codes and ordinances.

DANGER – Improper connection of the equipment-grounding conductor can result in a risk of electric shock. The conductor with insulation having an outer surface that is green with or without yellow stripes is the equipment-grounding conductor. If repair or replacement of the cord or plug is necessary, do not connect the equipment-grounding conductor to a live terminal. Check with a qualified electrician or serviceman if the grounding instructions are not completely understood, or if in doubt as to whether the appliance is properly grounded. Do not modify the plug provided with the appliance – if it will not fit the outlet, have a proper outlet installed by a qualified electrician.

This appliance is for use on a nominal 120 V circuit, and has a grounding plug that looks like the plug illustrated in sketch A in Figure. A temporary adaptor, which looks like the adaptor illustrated in sketches B and C, may be used to connect this plug to a 2-pole receptacle as shown in sketch B if a properly grounded outlet is not available. The temporary adaptor should be used only until a properly grounded outlet can be installed by a qualified electrician. The green colored rigid ear, lug, and the like, extending from the adaptor must be connected to a permanent ground such as a properly grounded outlet box cover. Whenever the adaptor is used, it must be held in place by the metal screw.

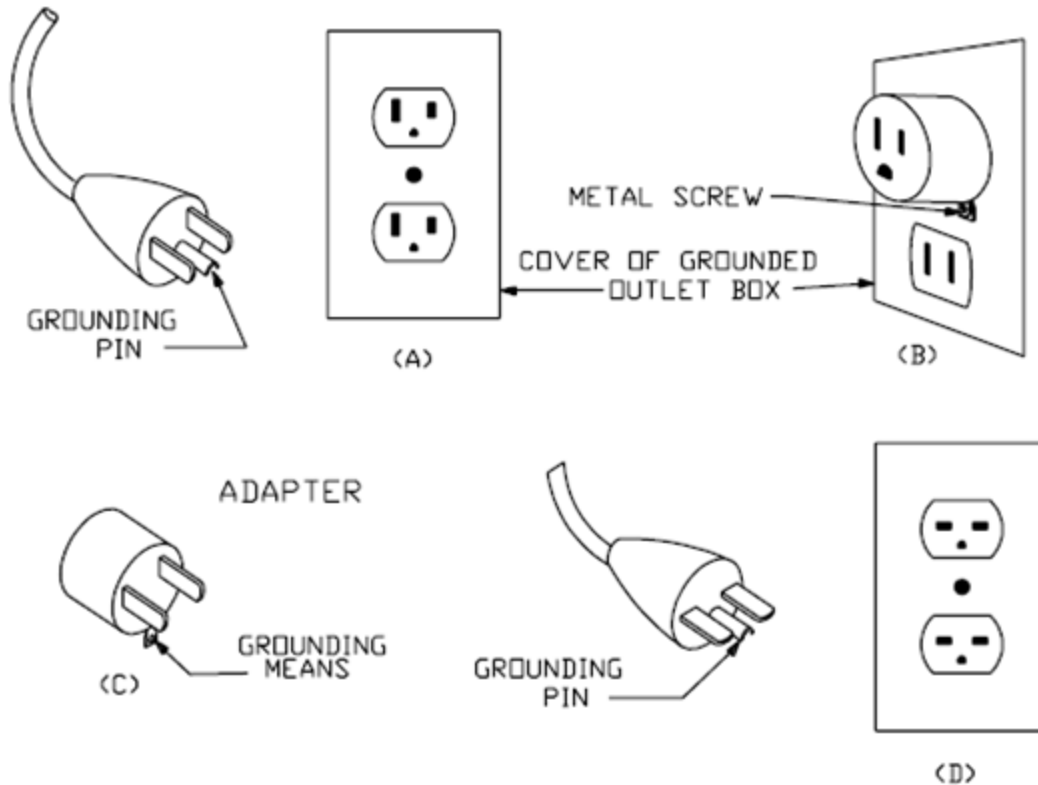



C08AF3S001