

Overview

The control surface with single large touch panel display and 26 faders enables you to perform general operation on the RIVAGE PM system. A CS-R10-S can be added to a RIVAGE PM system to provide dual-console control and flexibility. Dual power supply units are built in for high reliability.



Rear Panel

Features

- Fader configuration: 26 (12+12+2) faders.
- Touch Screen: 15" x 1
- Local I/O: 8 in, 8 out.
- Yamaha's industry-standard Selected Channel concept, providing direct access to parameters of any channel selected via its SEL key.
- Up to 8 I/O rack units can be connected to each console.
- Up to 2 DSP engine units can be connected to each console.
- Seamlessly integrated remote control and offline editing via an Apple iPad® or other computer.
- Data exchangeable using Console File Converter.
- Direct 2-track recording to standard USB flash drives, or serious multitrack recording to a DAW via Dante.
- Multitrack recordings can be used for "virtual sound checks" when the performers aren't available.
- Expansion Slots: MY Slot: 2
- GPI Interface: 8-in/8-out
- Other features: comprehensive Fader Bank section with recallable custom banks, editable channel names and colors, user defined keys and user defined knobs, 1000 scene memories, input and output delays, ample EQ and dynamics processing, 24 DCA groups, 12 mute groups, multiple user defined key and knob, and more.

Specifications

1/3

Functional Specifications (with DSP-R10)

Mixing Capacity	Input Mixing Channels	144mono (with DSP-R10)	Input Channel Functions	Direct Out	Yes	
	Mix Buses	72		Output Channel Functions	PEQ	8 Band Full PEQ
	Matrices	36 (Input to Matrix supported)			GEQ	Plug-in
	Stereo Buses	2			Dynamics 1	Legacy Comp / Comp260 / Gate / De-Esser / Expander / Ducking
	Mono Buses	1			Output Channel Delay	Yes (0ms ~ 1000ms)
	Cue Bus	2			MUTE Group	12
Local Connectors	Analog Input	8	Plug-in		Number of Slots	384
	Analog Output	8		Number of Effect Programs	50	
	HY Slots	4 (DSP-R10)	GEQ Rack	Number of GEQ Racks	48	
	MY Slots	2 (CS-R10) / 2 (DSP-R10)		Mountable Device	31BandGEQ / Flex15GEQ / 8Band PEQ (RTA overlay support)	
	Digital In	4 (AES/EBU)	TWINLANE	Number of I/O Channels	256 in / 256 out (with HY256-TL)	
	Digital Out	4 (AES/EBU)		Dante	Number of I/O Channels	144 in / 144 out (with HY144-D)
	GPI IN	8 (CS-R10) / 8 (DSP-R10)	Recording		USB Memory Recording	Yes
	GPI OUT	8 (CS-R10) / 8 (DSP-R10)		DVS Recording	Yes (with HY144-D)	
	Word Clock I/O	Only Out (CS-R10), In / Out (DSP-R10)	Broadcast Functions	5.1 Surround Panning	Yes (V2.0 or later)	
	MIDI I/O	In / Out (CS-R10), In / Out (DSP-R10)		Surround Monitor	Yes (V2.0 or later)	
	USB	4 (File Save/Load), 1 (2 Track Rec/Play)		Mix Minus	Yes (V2.0 or later)	
	External Redundant PSU	Built-in dual power supply		L-Mono / R-Mono / LR-Mono	No	
	Meter Bridge	4 (CS-R10) / 3 (CS-R10-S)	Monitor	Solo Mode	Yes	
	Ethernet	Yes		Oscillator	Sine Wave 1ch / Sine Wave 2ch / Pink Noise / Burst Noise	
	Lamp	3	Other Functions	Port to Port	Yes (V1.5 or later)	
	Talkback In	Yes		Dual Console	Yes (V2.0 or later)	
	Video Out	Yes		DSP Mirroring	Yes (V2.0 or later)	
	TC In	Yes (DSP-R10)		Timecode Reader/Display	Yes (V2.0 or later)	
	Fault Output	Yes (DSP-R10)		Timecode Chase (Event List)	Yes (V2.0 or later)	
	Phones	2 connectors (CS-R10-S)		GPI/MIDI	Yes	
AC Inlet	CS-R10: 2 (V-Lock Type), DSP-R10: 2 (V-Lock Type)	RTA		Yes		
Scene Memory	Number of Scenes	1000		Output Port Delay	Yes (0ms ~ 1000ms)	
	Recall Safe	Yes		Cascade	Yes (Future Update)	
	Focus Recall	Yes		User Interface	Display	15 inch Touch Panel x2
	Fade Time	Yes (0s ~ 60s)	Centralogic Section		Yes	
	Preview	Yes (V2.0 or later)	Faders		12+12+2	
	Selective Load / Save	Yes (V1.5 or later)	Selected Channel Encoders		All Parameters	
	Global Paste	Yes (V1.2 or later)	Channel Encoder		Yes	
	Event List	Yes (V2.0 or later with timecode trigger)	Channel Name / Color Display		Yes	
Overlay	Yes (V1.2 or later)	Custom Fader Banks	Yes (6 x 2 on each bay)			
Isolate	Yes	User Defined Keys	12 (x 4 banks)			
Input Channel Functions	Tactile Control Keys	Yes	User Defined Knobs	4 (x 4 banks)		
	Gain Compensation	Yes	Touch and Turn Knob	Yes		
	Silk	Yes (with RPiO and OMNI IN)	Monitor Level Knob	Yes (2: A and B)		
	Digital Gain	Yes (-96dB ~ +24dB)	Wooden Arm Rest	Yes		
	ATT	No	Software	Editor	RIVAGE PM Editor	
	HPF	20Hz~2000Hz, -6/-12/-18/-24dB/oct Selectable		StageMix	RIVAGE PM StageMix	
	PEQ	4 Band Full PEQ (4 algorithms, RTA overlay support)		MonitorMix	Yes (Future Update)	
	Dynamics 1	Legacy Comp / Comp260 / Gate / De-Esser / Expander / Ducking		Nuendo Live: Control integration	Yes (Future Update)	
	Dynamics 2	Legacy Comp / Comp260 / Gate / De-Esser / Expander / Ducking		Console File Converter	Yes	
	Input Delay	Yes (0ms ~ 1000ms)				
	Pan	Center Nominal				
	DCA Group	24 (Output DCA support)				
DCA Rollout	Yes					
MUTE Group	12					
Number of Inserts	4 slots on each 2 insert point					

Specifications

2/3

General Specifications

At the time of measurement, all faders are set to nominal. Output impedance of the signal generator is 150Ω.

Frequency Response

Fs=44.1kHz, 48kHz, 88.2kHz, 96kHz @20Hz-20kHz, reference to the nominal output level @ 1kHz

Inputs	Outputs	RL	Conditions	Min.	Typ.	Max.	Unit
OMNI IN 1-8	OMNI OUT 1-8	600Ω	GAIN: +66 dB	-0.8	0.0	0.5	dB

Total Harmonic Distortion *1

Fs=44.1kHz, 48kHz, 88.2kHz, 96kHz

Inputs	Outputs	RL	Conditions	Min.	Typ.	Max.	Unit
OMNI IN 1-8	OMNI OUT 1-8	600Ω	+4 dBu@20 Hz-20 kHz, GAIN:+66 dB			0.12	%
OMNI IN 1-8	OMNI OUT 1-8	600Ω	+4 dBu@20 Hz-20 kHz, GAIN:-6 dB			0.05	%
Internal OSC	OMNI OUT 1-8	600Ω	Full scale output@1 kHz			0.02	%
Internal OSC	PHONES	8Ω	Full scale output@1 kHz, phones level control: max			0.2	%

*1 An 80kHz, 18dB/octave low pass filter is used to measure total harmonic distortion.

Hum & Noise *1

Fs=44.1kHz, 48kHz, 88.2kHz, 96kHz

Inputs	Outputs	RL	Conditions	Min.	Typ.	Max.	Unit
OMNI IN 1-8	OMNI OUT 1-8	600Ω	RS= 150Ω, GAIN: +66 dB Master fader at nominal level and one Ch fader at nominal level.		-128		dBu
					-62		dBu
OMNI IN 1-8	OMNI OUT 1-8	600Ω	RS= 150Ω, GAIN: -6 dB Master fader at nominal level and one Ch fader at nominal level.	-90		-85	dBu
All Inputs	OMNI OUT 1-8	600Ω	RS= 150Ω, GAIN: -6 dB Master fader at nominal level and all OMNI IN 1-8 faders at nominal level.			-76	dBu
-	OMNI OUT 1-8	600Ω	Residual output noise, ST master off.		-92		dBu
-	PHONES	8Ω	Residual output noise, phones level control min.			-88	dBu

*1 An IHF-A filter is used to measure hum & noise level.

*2 EIN stands for Equivalent Input Noise.

Dynamic Range *1

Fs=44.1kHz, 48kHz, 88.2kHz, 96kHz

Inputs	Outputs	RL	Conditions	Min.	Typ.	Max.	Unit
OMNI IN 1-8	OMNI OUT 1-8	600Ω	AD +DA, GAIN: -6 dB		114		dB
-	OMNI OUT 1-8	600Ω	DA Converter		116		dB

*1 An IHF-A filter is used to measure dynamic range.

Crosstalk *1

@1 kHz Fs=44.1kHz, 48kHz, 88.2kHz, 96kHz

From/To	To/From	Conditions	Min.	Typ.	Max.	Unit
OMNI IN n	OMNI IN (n-1) or (n + 1)	OMNI IN 1-8 adjacent inputs, GAIN:-6 dB			-100	dB
OMNI OUT n	OMNI OUT (n-1) or (n + 1)	OMNI OUT 1-8, input to output			-100	dB

*1 A 22kHz, 30 dB/octave low pass filter is used to measure crosstalk.

Sampling Frequency

		Conditions	Min.	Typ.	Max.	Unit
External Clock	Frequency Range	Fs=44.1kHz, 48kHz, 88.2kHz, 96kHz	-1000	-	+1000	ppm
	Jitter of PLL *1	DIGITAL IN Fs=44.1kHz, 48kHz, 88.2kHz, 96kHz	-	-	10	ns
Internal Clock	Frequency	Word clock:int 44.1 kHz	-	44.1	-	kHz
		Word clock:int 48 kHz		48		
		Word clock:int 88.2 kHz		88.2		
Internal Clock	Accuracy	Word clock: int 44.1 kHz, 48 kHz, 88.2 kHz, 96 kHz	-50	-	+50	ppm
		Jitter *2	Word clock:int 44.1 kHz	-	-	4.5
Word clock:int 48 kHz				4.1		
Word clock:int 88.2 kHz				2.3		
		Word clock:int 96 kHz			2.1	

*1 Input clock jitter must be 1 ns or less.

*2 Measured at the WORD CLOCK OUT connector.

Power Requirements

	Conditions	Min.	Typ.	Max.	Unit
Power Consumption	100-240V 50/60 Hz	-	-	380	W
Heating Value	100-240V 50/60 Hz	-	-	330	kcal/h

Power Cable Length and Temperature Range

	Conditions	Min.	Typ.	Max.	Unit
Power Cord Length		-	250	-	cm
Temperature Range	Operating Temperature Range	0	-	40	°C
	Storage Temperature Range	-20	-	60	°C

Specifications

3/3

Analog Input Characteristics *1 *2 *3

Input Jack	GAIN	Input Impedance	Source Impedance	Input Level			Connector
				Sensitivity ⁴	Nominal	Max. before Clip	
OMNI IN 1-8	+66 dB	10kΩ	50-600Ω Mics & 600Ω Lines	-82dBu (61.6μV)	-62dBu (0.616mV)	-42dBu (6.16mV)	XLR-3-31 type (Balanced) ⁵
	-6 dB			-10dBu (245mV)	+10dBu (2.45V)	+30dBu (24.5V)	
TALKBACK	+54 dB	10kΩ	50-600Ω Mics & 600Ω Lines	-70dBu (245μV)	-50dBu (2.45mV)	-30dBu (24.5mV)	XLR-3-31 type (Balanced) ⁵
	-6 dB			-10dBu (245mV)	+10dBu (2.45V)	+30dBu (24.5V)	

*1 0dBu= 0.775 Vrms for all specifications

*2 All AD converters are 24bit linear.

*3 OMNI IN jacks 1-8 and the TALKBACK XLR jack feature +48V DC phantom power which is switchable for each jack individually from the unit's software.

*4 Sensitivity is defined as the input level required to produce an output of +4dBu (1.23V) or the nominal output level when all faders and level controls are set to maximum.

*5 Connectors are balanced. (1= GND, 2= HOT, 3= COLD)

Analog Output Characteristics *1 *2 *3

Output Jacks	Output Impedance	Load Impedance	Max Output Level Select Switch *4 *5	Output Level		Connector
				Nominal	Max. before Clip	
OMNI OUT 1-8	75Ω	600Ω Lines	+24dB (default)	+4dBu (1.23V)	+24dBu (12.3V)	XLR-3-32 type (Balanced) ⁷
			+18dB	-2dBu (0.616V)	+18dBu (6.16V)	
			+15dB	-5dBu (0.436V)	+15dBu (4.36V)	
PHONES A, B (1/2 *3)	15Ω	8Ω Phones	-	75mW ⁶	150mW	Stereo Phone Jack (TRS) (Unbalanced) ⁸
		40Ω Phones	-	65mW ⁶	150mW	

*1 0dBu= 0.775 Vrms for all specifications

*2 All DA converters are 24bit linear.

*3 PHONES A, B 1/2 (CS-R10), PHONES A/B (CS-R10S)

*4 The unit features an internal switch to change the maximum output level.

*5 The 24dBu switch position can be changed for fee so that the output level will be + 20dBu.

*6 These measurements were obtained when the PHONES A/B LEVEL knobs are set 10 dB lower than the maximum.

*7 Connectors are balanced. (1= GND, 2= HOT, 3= COLD)

*8 Connectors are unbalanced. (Tip=LEFT, Ring= RIGHT, Sleeve= GND)

Digital Input & Output Characteristics

Jack	Format	Data Length	Level	Connector
AES/EBU IN 1/2, 3/4, 5/6, 7/8 *1	AES/EBU	24bit	RS422	XLR-3-31 type (Balanced) ²
AES/EBU OUT 1/2, 3/4, 5/6, 7/8 *1	AES/EBU	24bit	RS422	XLR-3-32 type (Balanced) ²

*1 Features sampling rate converters.

Input SRC

Supported input frequency (conversion source): 44.1 kHz-4%-200ppm - 96 kHz+4.1667%+200 ppm

Output SRC

Supported output frequency (conversion destination): 44.1 kHz-4%-200ppm - 96 kHz+4.1667%+200 ppm

*2 Connectors are balanced. (1= GND, 2= HOT, 3= COLD)

Control I/O Characteristics

Terminal	Format	Level	Connector	
WORD CLOCK	OUT	-	TTL/75Ω	BNC
MIDI	IN	MIDI	-	DIN 5P
	OUT	MIDI	-	DIN 5P
USB 1-4	USB 2.0 Host	USB	USB A Connector (Female)	
RECORDING *1	USB 2.0 Host	USB	USB A Connector (Female)	
VIDEO OUT	-	DVI-D	DVI	
NETWORK [PC]	IEEE802.3	10BASE-T/100BASE-TX	EtherCON CAT5 *2 *3	
To ENGINE IN/OUT	-	1000BASE-T	EtherCON CAT5e *3 *4	
GPI *5	-	-	D Sub Connector (25P Female)	
LAMP 1-3	-	0V-12V	XLR-4-31 type *6	

*1 Supported file formats are WAV and MP3.

*2 CAT5 or higher cables are used for connections.

*3 STP cables are recommended for connections.

*4 CAT5e or higher cables are used for connections.

*5 Input pin

CH1-7 TTL level (input voltage 0-5V)

CH8 Photo coupler (input voltage 0-24V, low level: 1V or lower, high level: 5V or higher)

Output pin

CH1-7 Open drain output (max supply voltage 12V, max. sink current/pin 75mA)

CH8 Relay contact (max. 1A/30VDC)

Power supply pin

Output voltage 5 V±5%, max. output current 600mA

*6 4-pin=+12V, 3-pin=GND; Up to 5 W is supported for lamp rating.

Others

Dimensions (W x H x D), Weight	1128mm x 417mm x 848mm (44.4" x 16.4" x 33.4") *1, 67kg (147.7lbs)
Accessories	System set up guide, AC power cord x 2, Dust cover Gooseneck Lamp LA1L x 3
Fader	Touch-sensitive 100mm motorized fader: resolution +10dB to -138dB, -∞dB (1024 steps)
NC Value	Low mode: NC=15 / High mode: NC=25 *2

*1 Including the rubber feet

*2 Measuring position: 30cm horizontally away and vertically up from the unit (front pad)

Dimensions

Unit: mm (inch)

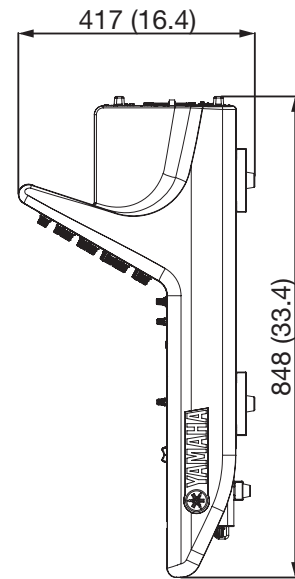
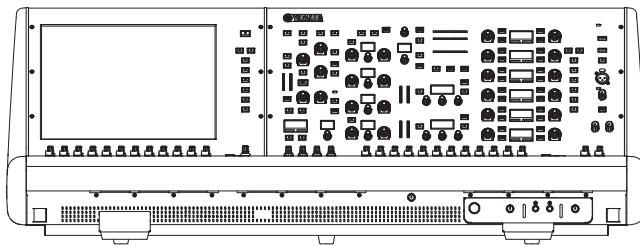
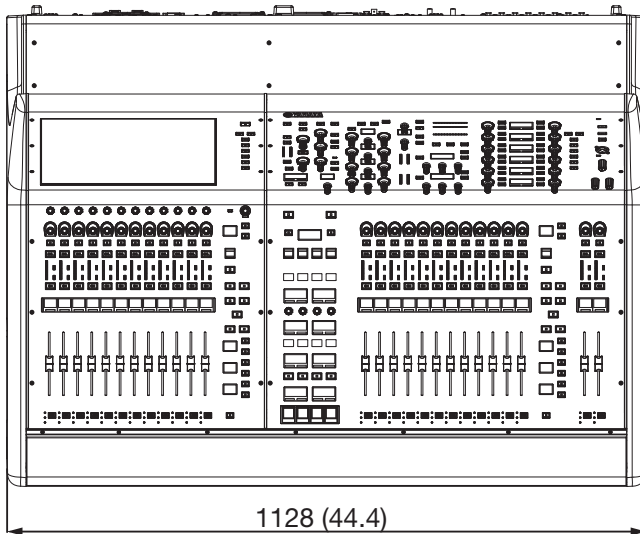
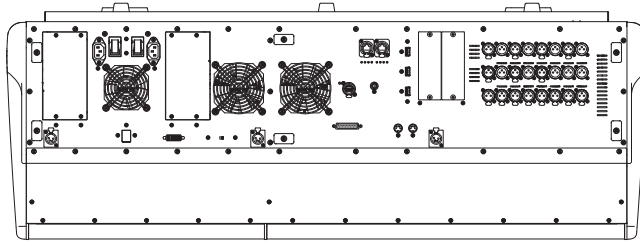

Architectural and Engineering Specifications

The Yamaha CS-R10-S shall be a control surface for use with the Yamaha RIVAGE PM10 Digital Mixing System. CS-R10-S shall adopt TWINLANe network connectivity and it shall build a console network with low latency. Selected Channel shall provide direct access to parameters of any channel selected via its SEL key. It shall include 12 faders in the left section and 12 fader in the right section plus 2 master faders. All the faders are touch-sensitive 100mm motorized faders. The CS-R10-S shall provide functions for fast, efficient mixing via an intuitive interface. It shall include a 15" touch-screen Multi Function Display. Physical controllers other than faders shall include the Selected Channel controllers, 12 x 4 banks User Defined Keys, 4 x 4 banks User Defined Knobs, and 2 Touch and Turn knob provides directly and intuitively controllability. Local I/O shall include 8 analog microphone/line inputs and 8 outputs, 4 AES/EBU inputs and output (with SRC), GPI ports (8 in/8 out), word clock I/O, MIDI I/O, network port, 5 USB (1 for 2-track recording), and Video Out (DVI-D). It shall be Dual redundant power supply and power consumption shall be 380W. Dimensions shall be 1128 (W) x 417 (H) x 848 (D) mm. Weight shall be 67 kg.

Block Diagrams

Control Surface, I/O Rack, DSP Engine

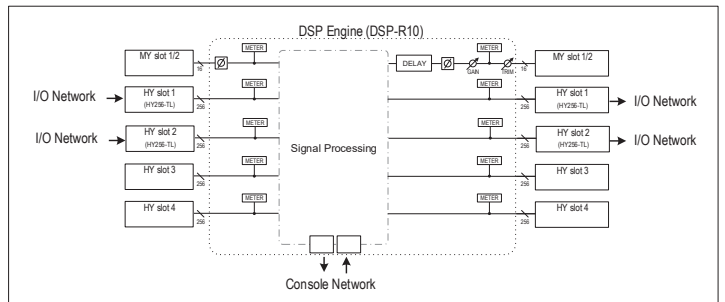
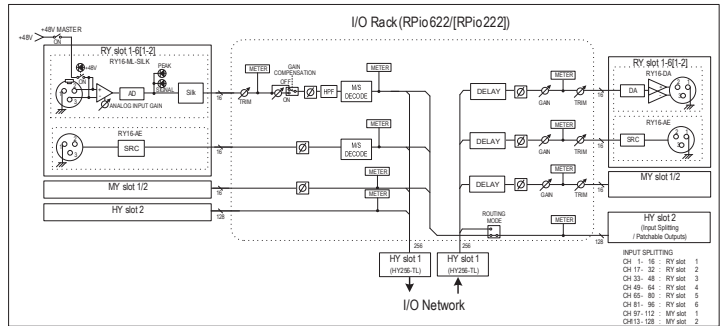
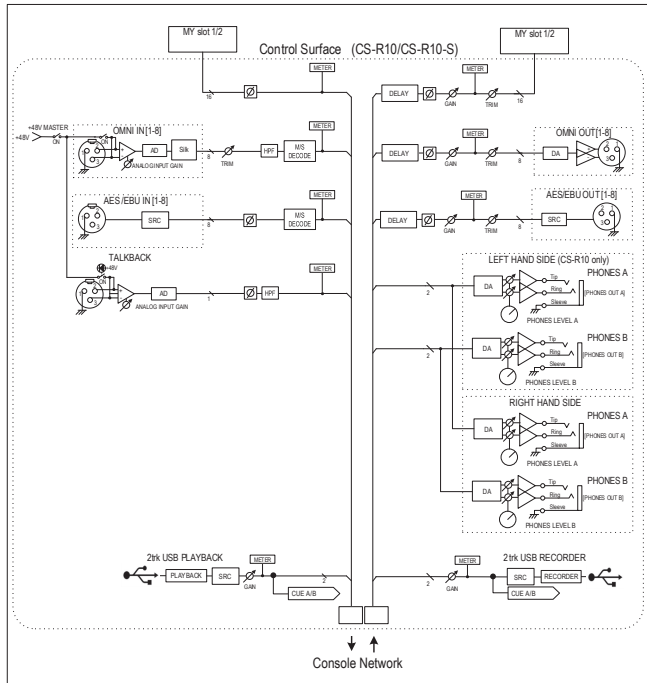

Block Diagrams

MIX 1-72

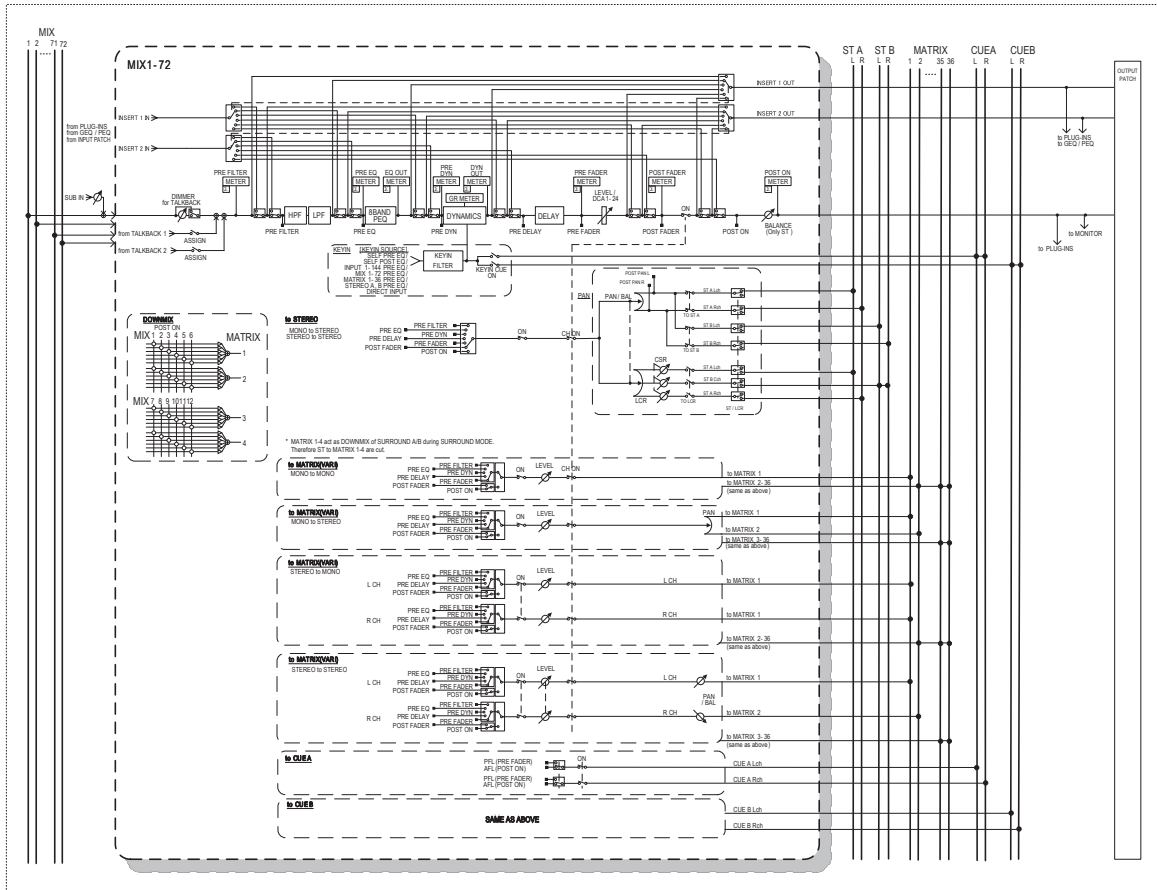

Block Diagrams

STEREO A/B

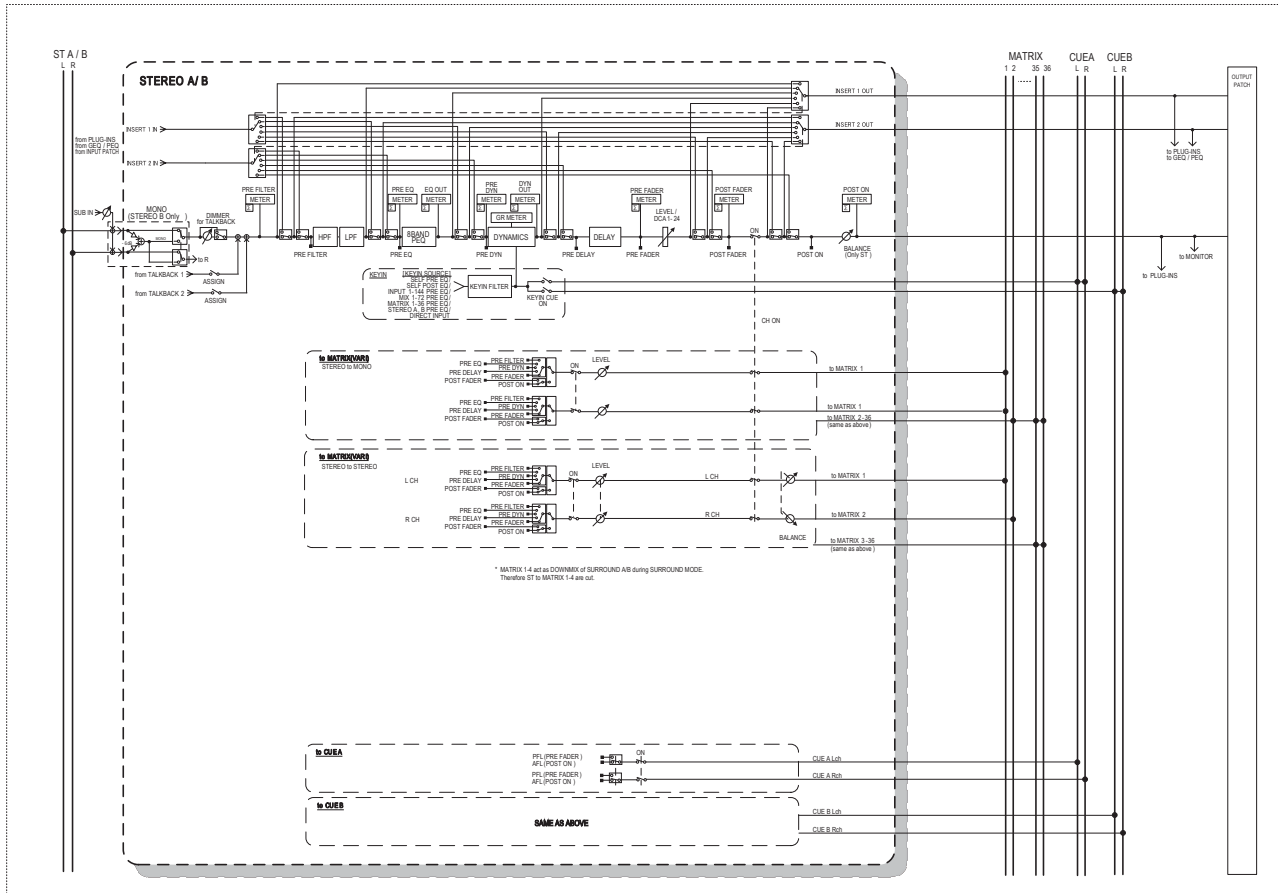

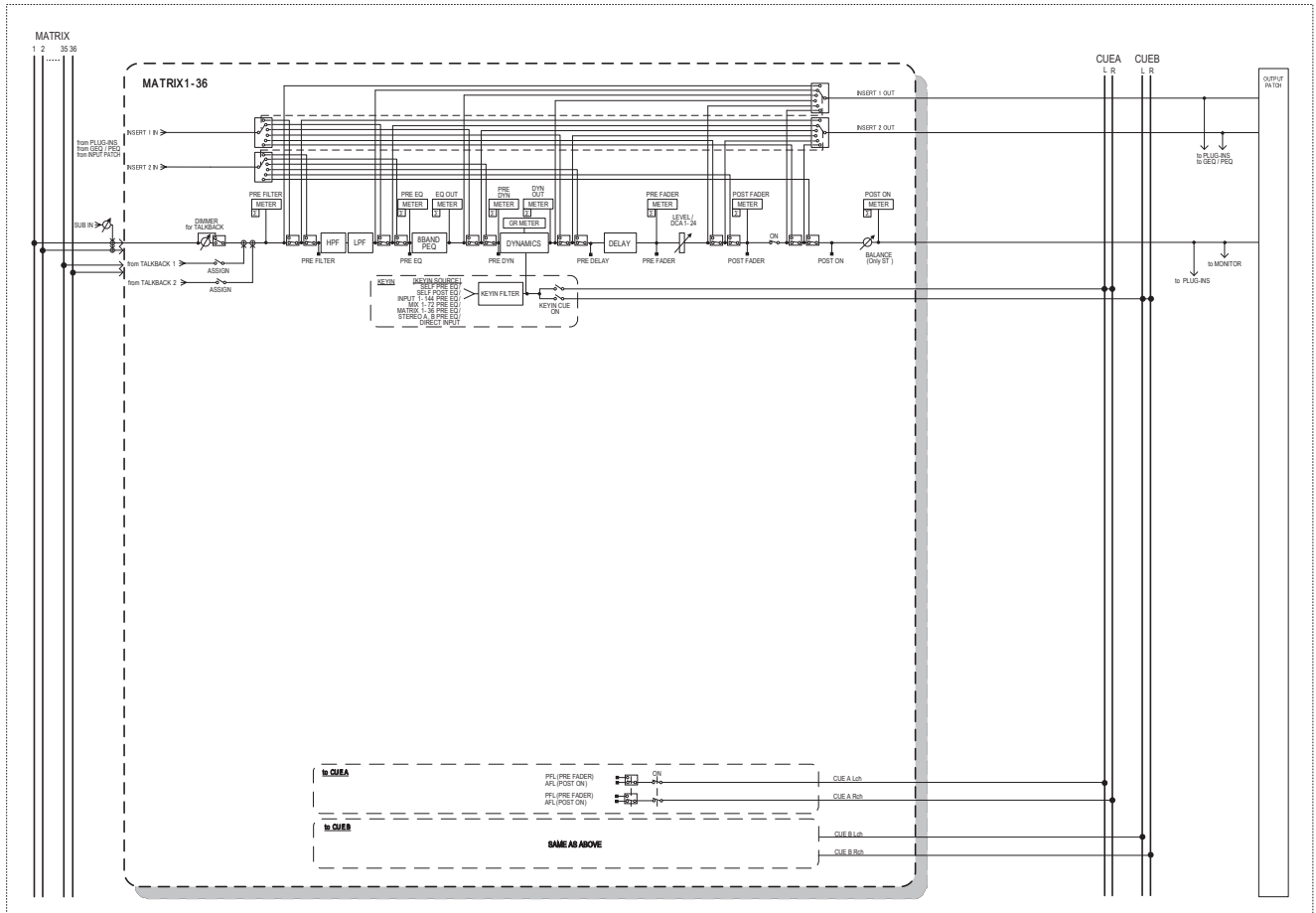
Block Diagrams
MATRIX 1-36

Block Diagrams

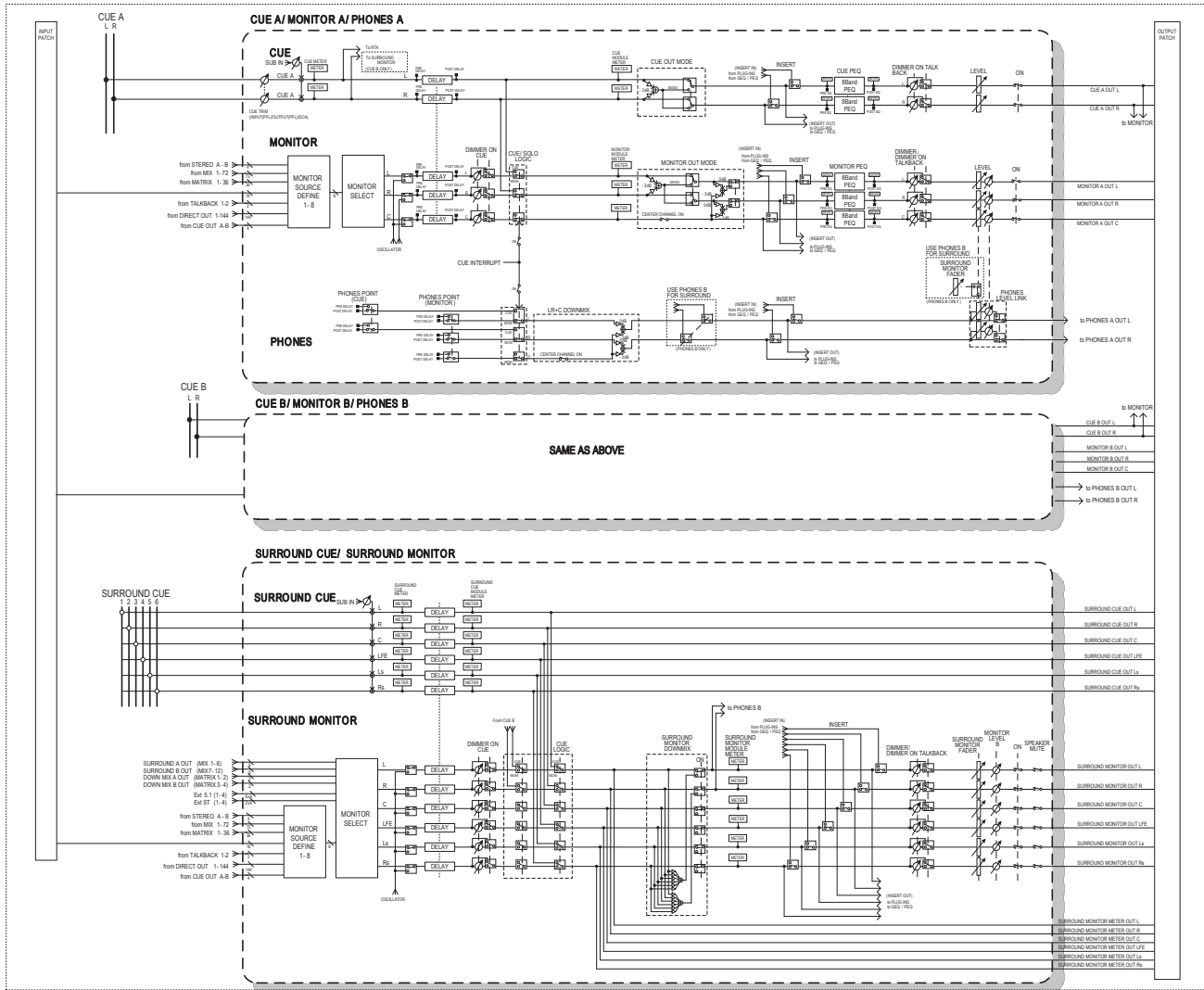
CUE/MONITOR/MISC.

Block Diagrams

