

Centraverse Desktop Base



The Shure Centraverse CVD is a sleek desktop base that is compatible with all Centraverse 12" and 18" gooseneck microphones. Featuring CommShield[®] technology, it provides RF interference immunity and transparently passes audio from the gooseneck microphone to a sound reinforcement system.

Features

- Black finish that blends unobtrusively with most surroundings
- Attached 12 ft XLR cable can run through the back or bottom of the base
- Mounting holes for secure installation
- Compatible with all Centraverse gooseneck microphones

Installation

1. Install two screws into the mounting surface, exactly 14 mm (9/16 in.) apart. Leave a 5 mm (3/16 in.) gap between the screw head and the mounting surface. Only use screws with a flat-bottom head.
2. Place the microphone onto the screws and slide backwards to lock into place. The cable can be routed through either the back or the bottom of the base.
3. Connect the gooseneck microphone to the base (microphone sold separately).
4. Connect the integrated XLR cable to a mixer or P.A. system.

Note: This microphone requires +48V phantom power to operate.

For additional information on product use, see the user guide for the Shure Centraverse CVG Gooseneck microphone.

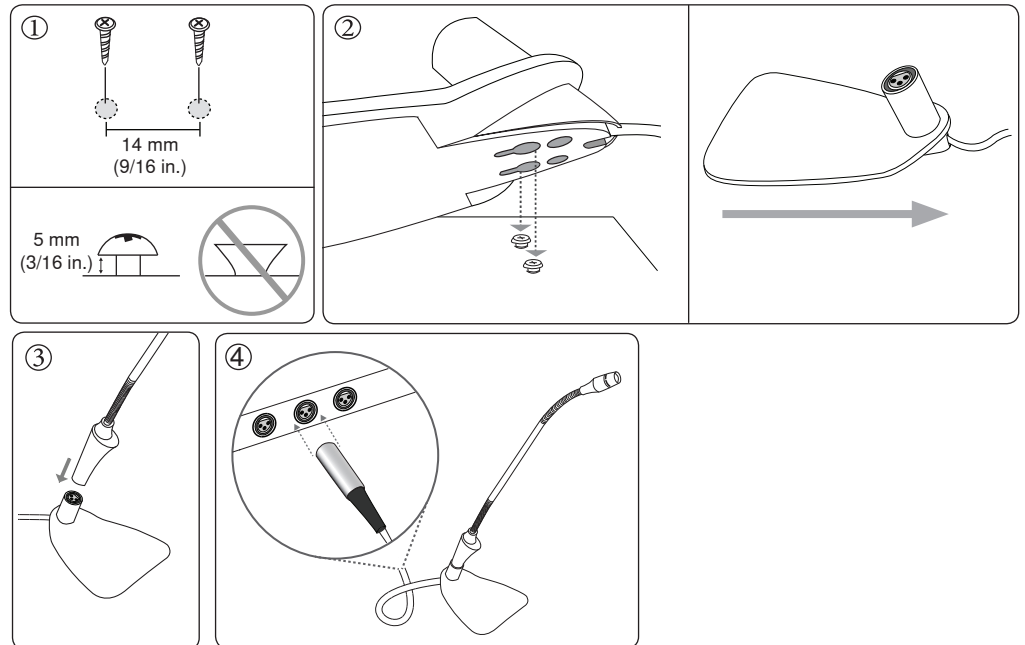

Specifications

Polarity

Positive pressure on diaphragm produces positive voltage on pin 2 with respect to pin 3

Environmental Conditions

Operating Temperature	-18 to 57°C (0 to 135°F)
Storage Temperature	-29 to 74°C (-20 to 165°F)
Relative Humidity	0 to 95%

Weight

19.2 oz. (544 g)

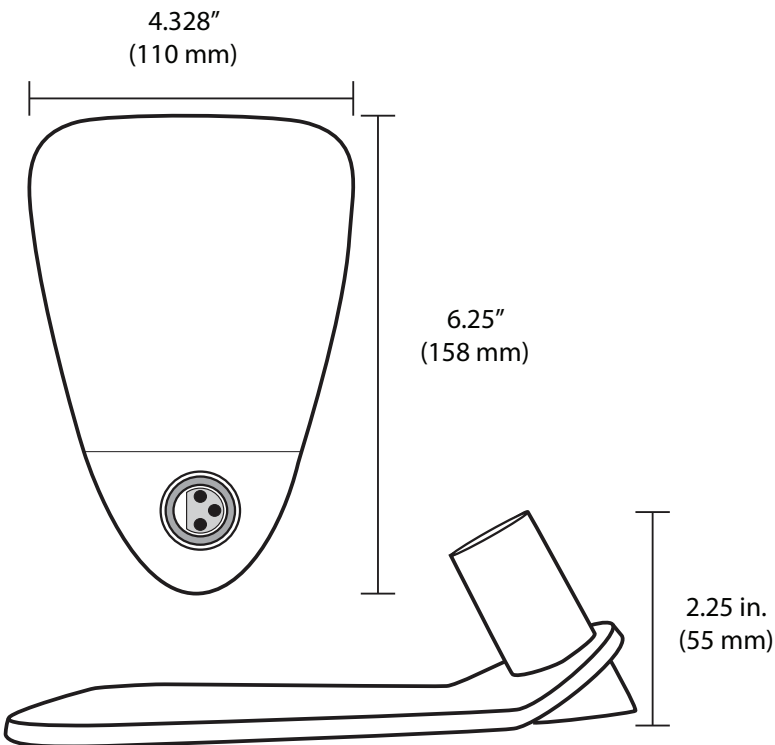

Certifications

Meets essential requirements of all applicable European Directives.

Eligible for CE marking.

The CE Declaration of Conformity can be obtained from Shure Incorporated or any of its European representatives. For contact information please visit www.shure.com

The CE Declaration of Conformity can be obtained from: www.shure.com/europe/compliance

Authorized European representative:

Shure Europe GmbH

Headquarters Europe, Middle East & Africa

Department: EMEA Approval

Jakob-Dieffenbacher-Str. 12

75031 Eppingen, Germany

Phone: 49-7262-92 49 0

Fax: 49-7262-92 49 11 4

Email: EMEAsupport@shure.de

SHURE®

SHURE Incorporated <http://www.shure.com>

United States, Canada, Latin America, Caribbean:

5800 W. Touhy Avenue, Niles, IL 60714-4608, U.S.A.

Phone: 847-600-2000 U.S. Fax: 847-600-1212 Int'l Fax: 847-600-6446

Europe, Middle East, Africa:

Shure Europe GmbH, Phone: 49-7262-92490 Fax: 49-7262-9249114

Asia, Pacific:

Shure Asia Limited, Phone: 852-2893-4290 Fax: 852-2893-4055