

# EBP 104 MK

## eBUS BUTTON PANEL WITH 4 BUTTONS - MK

- ▶ Fully customizable button panel integrates easily with an Extron Pro Series control system
- ▶ Four dual-color, customizable, back-lit buttons
- ▶ Two eBUS ports allow for quick system expansion and upgrades
- ▶ Use a single button panel or combine multiple button panels to accommodate a broad variety of system designs
- ▶ DIP switches are used to set unique eBUS device addresses and minimize setup time
- ▶ Includes white MK wall frame and mounting bracket

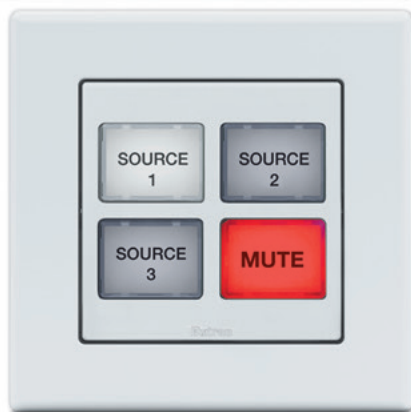

The Extron EBP 104 MK eBUS® Button Panel is a fully-customizable AV system control interface designed for use with Extron eBUS-enabled control systems. This easy-to-use control panel connects to an IPCP Pro control processor to perform a wide variety of AV system functions such as display On/Off, input switching, volume control, and much more. Four dual colored backlit buttons provide easy operation in low-light environments. eBUS button panels are linked to the control processor and to each other using a single cable that carries both power and communication.



## DESCRIPTION

eBUS button panels connect using a unique digital bus architecture that allows for easy control system expansion, greater design options, and future upgrades. Button panels are linked to the control processor and to each other using a single cable that carries both power and communication. This efficient, expandable design allows a button panel to be used as a single user interface in a smaller system or combined with other button panels and touchpanels when a more elaborate control system is required.

Since eBUS button panels have the same physical appearance as Extron's broad range of MediaLink controllers, they can be used alongside them throughout a facility while preserving a consistent look and user experience. Button panels are available with 3 to 14 buttons with convenient button arrangements to suit a broad range of room control needs. Buttons on the EBP 104 MK can be easily customized using Extron Button Label Generator software.

## APPLICATION DIAGRAM

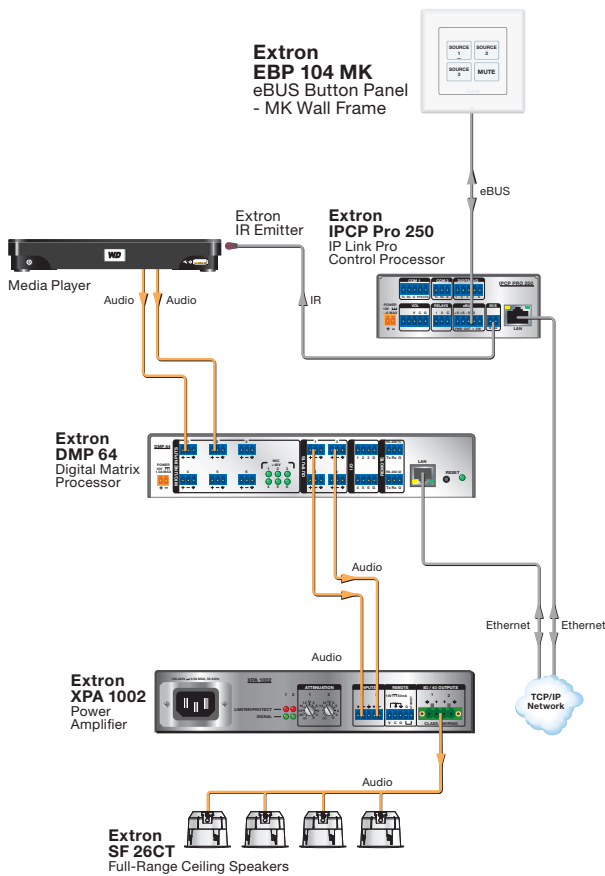

## SPECIFICATIONS

| EBUS CONTROL INTERFACE       |  |             |
|------------------------------|--|-------------|
| eBUS control ports           | (2) 3.5 mm captive screw connectors, 4 pole  |             |
| eBUS pin configuration       | +V = +12 VDC; +S = + signal; -S = - signal; G = ground   |             |
| Recommended cable type       | Extron STP20-2/1000 or STP20-2P/1000 cable   |             |
| Maximum system cable length  | 1000 feet (305 meters) sum total for the eBUS system, regardless of topology. Power injection may be required depending on system cabling topology and primary power supply wattage. See the eBUS® Button Panel EU and MK Series Setup Guide or eBUS Technology Reference Guide for details.   |             |
| SOFTWARE AND CONTROL OPTIONS |  |             |
| Configuration software       | Global Configurator Plus and Professional  |             |
| Programming software         | Global Scripter  |             |
| Control apps                 | Extron Control   |             |
| Utilities                    | Toolbelt   |             |
| GENERAL                      |  |             |
| Power                        | 12 VDC (Power is supplied by an Extron IPCP Pro series control processor or optional power supply).  |             |
| Power consumption            | 0.5 W  |             |
| Enclosure dimensions         | <p>Faceplate: 3.39" H x 3.39" W x 0.45" D (86 mm H x 86 mm W x 12 mm D)<br/>(Depth includes faceplate and buttons.)</p> <p>Device: 1.80" H x 1.83" W x 1.08" D (46 mm H x 47 mm W x 28 mm D)<br/>1.80" H x 1.83" W x 1.48" D (46 mm H x 47 mm W x 38 mm D) including captive screw connectors<br/>(Allow enough depth in the junction box for device and cable clearance.)</p> |             |
| Product weight               | 0.2 lb (0.1 kg)  |             |
| Regulatory compliance        | <p>Safety: CE, c-UL, UL</p> <p>EMV/EMC: CE, C-Tick, FCC Class A, ICES, VCCI class A</p> <p>Environmental: Complies with the appropriate requirements of RoHS, WEEE</p> <p>Accessibility: Complies with the appropriate requirements of Section 508 of the Rehabilitation Act (29 U.S.C. 794d).</p>   |             |
| Warranty                     | 3 years parts and labor  |             |
|                              |  |             |
| Model                        | Version Description  | Part number |
| EBP 104 MK                   | MK Mount, White, 4 Button  | 60-1672-23  |

For complete specifications, please go to [www.extron.com](http://www.extron.com)  
Specifications are subject to change without notice.

### WORLDWIDE SALES OFFICES

Anaheim • Raleigh • Silicon Valley • Dallas • New York • Washington, DC • Toronto • Mexico City • Paris • London  
Frankfurt • Madrid • Stockholm • Amersfoort • Moscow • Dubai • Johannesburg • Tel Aviv • Sydney • Melbourne  
Bangalore • Mumbai • New Delhi • Singapore • Seoul • Shanghai • Beijing • Hong Kong • Tokyo

[www.extron.com](http://www.extron.com)