

The EMS-126 and EMS-129 are updated versions of the ever-popular EMS-122 and EMS-122w. They retain both the sonic character of the originals along with complete physical compatibility, yet are significantly lighter than the originals. As before, the two loudspeakers are narrow and wide dispersion variants of the same product. Utilising our latest passive crossover topologies, and the utmost in drive unit technology, these loudspeakers are completely passive yet outperform many bi-amplified or processed designs. The EMS-126/129 is ideal for front-of-house duty for small to medium venues, or as a powerful fill loudspeaker for larger systems. The multi-angle enclosure also allows use as a stage monitor if required.

## FEATURES AND BENEFITS

- Asymmetrical multi-angled cabinet for FOH or stage monitor use
- Genuine plywood cabinet for sonic benefit over plastic
- 12" neodymium LF, 1.4" exit neodymium HF drive units
- True passive design - no corrective DSP required
- Wide and narrow dispersion variants in identical enclosure footprints
- 35mm pole mount socket
- Rotatable waveguide: 90° x 60° (EMS-129), 60° x 40° (EMS-126)
- Flexible rigging and mounting options
- Compatible with OmniMount™ and Powerdrive brackets
- Impact and weather resistant black, and textured white finishes as standard
- RAL colour and weather protection options

## APPLICATIONS

- Live music venues
- Houses of worship
- Concert touring
- Fills for larger systems
- Conference, corporate and audio-visual

The EMS-126/129 is a two-way passive loudspeaker, using a 3" voice coil 12" (305mm) neodymium low frequency transducer. This low frequency drive unit is coupled via the internal passive crossover network to a 3" (76mm) diaphragm, 1.4" (36mm) exit neodymium high frequency transducer. This drive unit loads onto a constant-coverage horn, which yields not only consistent response throughout its operating band across the whole coverage pattern (60° by 40° for the EMS-126, 90° x 60° for the EMS-129, both rotatable) but also strong attenuation outside of this pattern. The result is a loudspeaker with extremely consistent and predictable coverage, as well as stunning sonic detail – and all with the ease of use that passive crossover technology brings.

The drive units are housed within a compact, vented enclosure. The robust enclosure is constructed from premium 15mm (5/8") multi-laminate Birch plywood, and is heavily braced to minimise panel reflection. Incorporated into the top and bottom of the enclosure are a pair of M10 threaded points for attachment of a variety of rigging and flying hardware,

and an M8 safety/pull-back point is provided on the rear of the enclosure. A 35mm pole mount socket is provided discretely on the underside for stand mounting. The enclosure also includes a flush bar handle on the rear, and a pair of Neutrik® speakON™ NL4 connectors for input and enclosure link. Lastly, a tough hex-punched grille backed with acoustically transparent fabric protects the drive units from damage. The grille can be quickly removed for service purposes or to rotate the HF waveguide – the orientation of which can be determined without removing the grille. The enclosure is finished in black impact and water-resistant polyurethane or white textured paint as standard, however RAL colour matching and increased weather resistant options are also available.

The EMS-126/129 requires a single amplifier channel, and should be used with professional power amplifiers capable of delivering 750-1000W RMS into an 8-ohm load. For optimal results, the DQ Series Advanced System Amplifiers should be used.



## TECHNICAL SPECIFICATIONS

ENCLOSURE TYPE:	Two-way passive, reflex loaded
DIMENSIONS (HxWxD):	622 (24.5) x 380 (15) x 364 (14.3) mm/(ins)
NET/SHIPPING WEIGHT:	25/27.5kg (55/60.5lbs) (EMS-126), 24/26.6kg (52.8/58.5lbs) (EMS-129)
FREQUENCY RESPONSE <sup>1</sup> :	70Hz – 20kHz ±3dB
SENSITIVITY <sup>2</sup> :	99dB
DISPERSION <sup>3</sup> :	60° x 40° (EMS-126) or 90° x 60° (EMS-129), rotatable
DRIVE UNITS:	12" (305mm) neodymium LF cone drive unit, 1.4" (36mm) exit HF compression drive unit
LOUDSPEAKERS PER AMPLIFIER:	DQ6: 2 per channel, DQ10: 4 per channel, DQ20: 4 per channel
POWER HANDLING:	500W RMS, 1000W program
MAXIMUM SPL <sup>4</sup> :	128dB continuous, 134dB peak
NOMINAL IMPEDANCE:	8 ohms
CROSSOVER:	Asymmetric internal passive
CONNECTORS:	2 x Neutrik® speakON™ NL4
ENCLOSURE:	15mm (5/8") multi-laminate Birch plywood – rebated, screwed and glued Finished in impact resistant textured paint
RIGGING & HARDWARE:	4 x M10 threaded mounting points (2 top/2 bottom) 1 x M8 threaded mounting point on rear 4 x M8 threaded points for OmniMount™ Series 60/Powerdrive™ Series 100 brackets 1 x flush handle on rear, 1 x 35mm pole mount socket
GRILLE:	Hex-punched steel backed with acoustically transparent fabric
OPTIONS:	Colours/Weather Protection
ACCESSORIES:	Colours/Weather Protection FC-129v vertical flying cradle VFA-129 variable angle flying bracket FC-129h horizontal flying cradle DFB-129 dual enclosure flying plate set
SPARE PARTS:	DU-1208 12" drive unit CDU-1404 1.4" exit HF compression drive unit RD-1404 replacement HF diaphragm PX-126 passive crossover assembly (EMS-126) PX-129 passive crossover assembly (EMS-129) RFG-129 replacement grille/fabric

### NOTES ON MEASUREMENT CONDITIONS:

<sup>1</sup>Measured on-axis at 2m in an anechoic environment and referenced to 1m. <sup>2</sup>Measured in half space at 2m with 4W sine wave input and referenced to 1m. <sup>3</sup>Nominal dispersion, measured in an anechoic environment and averaged over stated bandwidth. <sup>4</sup>Calculated and verified by subjective listening test of familiar program material.

## RIGGING ACCESSORIES

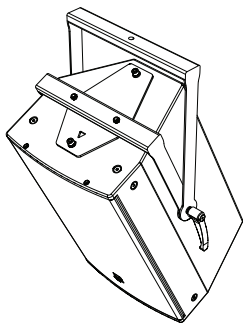

**FC-129v**

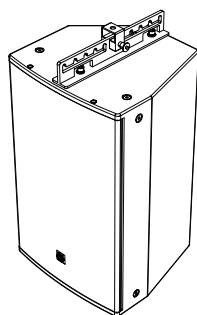

**VFA-129**

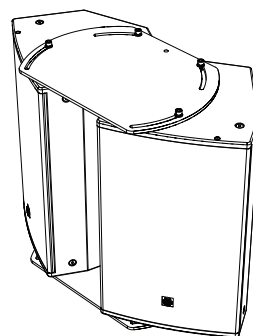

**DFB-129**

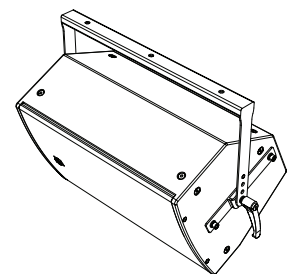

**FC-129h**

## ENCLOSURE OPTIONS

EMS-126/129 enclosures are available as standard in black 3-step impact resistant polyurethane finish, or white water-based Warnex textured paint. Custom RAL colours can be supplied on request; extended lead times and set up costs apply. EMS-126/129 enclosures can also be supplied as an outdoor version (OD), finished in the same black weather-resistant 3-step polyurethane coating, with stainless steel grilles and weather-resistant connector options, and other cabinet details bespoke to the customer's request. Custom RAL colours are also available for outdoor options by specific quote. Please contact your local EM Acoustics representative for details.

ENGINEERING DRAWING

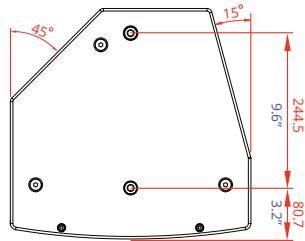

TOP

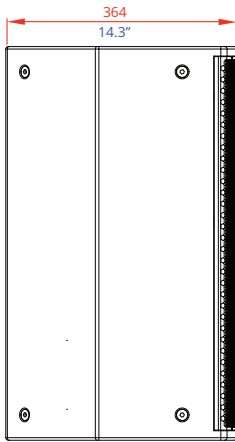

LEFT

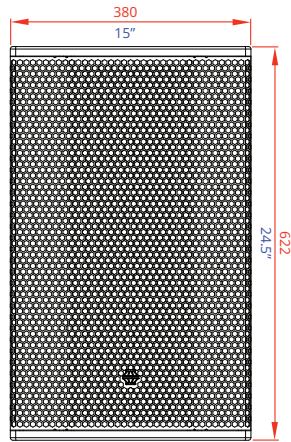

FRONT

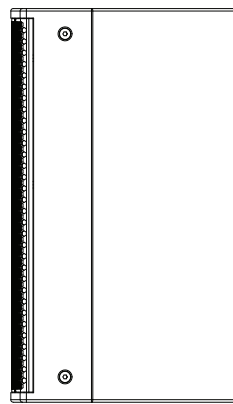

RIGHT

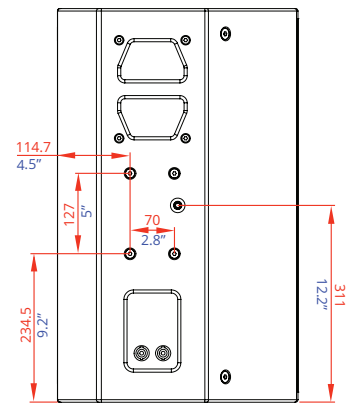

REAR

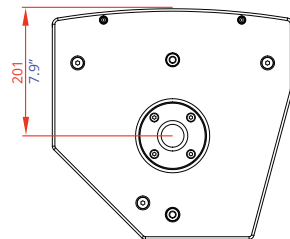

BOTTOM