

LIGHT SKY[®]

FLY DRAGON LIGHTING EQUIPMENT CO.,LTD

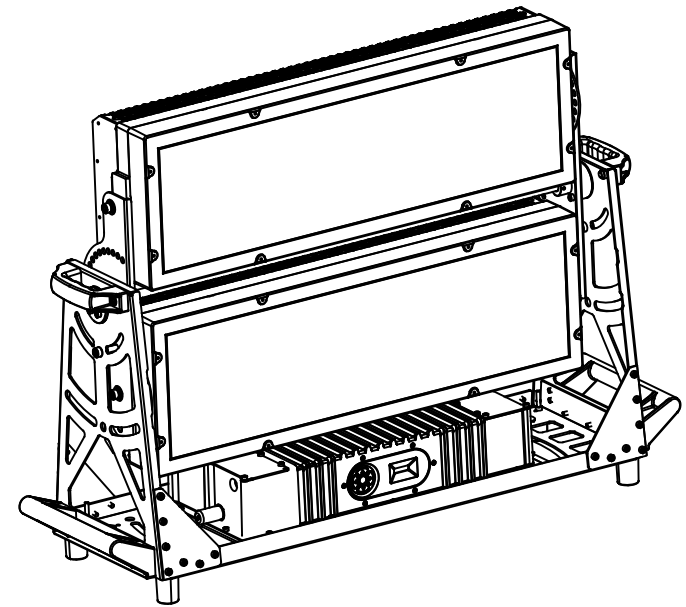

LIGHT SKY[®]

Tel:0086-20-61828288

Fax:0086-20-61828188 Pc:510800

Web:www.lightsky.com.cn

E-mail: flydragon@lightsky.com.cn

asia@lightsky.com.cn

india@lightsky.com.cn

europa@lightsky.com.cn

latinamerica@lightsky.com.cn

middle-east@lightsky.com.cn

american@lightsky.com.cn

Address: No. 43, Yunfeng Road, Xiuquan Street,
Huadu District, Guangzhou, China



LIGHT SKY[®]



SUNNY

USER MANUAL

Please read these user manual carefully before use

Contents

1. Safety information.....2

2. Technical information.....4

3. Attachment and body size.....6

4. Installation and connecting.....7

5. Control panel.....9

6. Menu setting.....10

7. Channel function.....12

8. Circuit connecting diagram.....24

9. Cleaning and maintenances.....25

10.Troubeshooting.....26

11.Duty exonerative and copyright protection.....27

Congratulations on choosing our company product! We thank you for your custom.

- ◆Please note that this product, as all the others in the rich my company range, has been designed and made with total quality to ensure excellent performance and best meet your expectations and requirements.
- ◆Carefully read this user manual in its entirety and keep it safe for future reference. It is essential to know the information and comply with the instructions given in this manual to ensure the fitting is installed, used and serviced correctly and safely.
- ◆My company disclaims all liability for damage to the fitting or to other property or persons deriving from installation, use and maintenance that have not been carried out in conformity with this user manual, which must always accompany the fitting.
- ◆My company reserves the right to modify the characteristics stated in this user manual at any time and without prior notice.

SAFETY INFORMATION



■ This lighting fixture is for professional use only - it is not for household use.

■ Installation

Make sure all parts for fixing the projector are in a good state of repair.

Make sure the point of anchorage is stable before positioning the projector.

Enhanced care has to be considered during the installation.

The safety chain must be properly hooked onto the fitting and secured to the framework.

The unit can be placed directly on the stage floor which can support 10 times of the unit's weight.



■ Mounting surface and fire protection

Please do not install the fixture onto combustible surface.

Keep all combustible materials at least 20 cm away from the fixture.

Make sure there are no flammable materials close to the unit while operating, as it is fire hazard.



ta 40°C

■ Maximum ambient temperature 最高环境温度

This fixture is suitable for indoor use and wet locations. Do not immerse in water.

The ambient temperature Ta: -20°C~40°C.



■ Protection against electrical shock

Connection must be made to a power supply system fitted with efficient earthing (**Class I** appliance according to standard EN 60598-1).

It is, moreover, recommended to protect the supply lines of the projectors from indirect contact and/or shorting to earth by using appropriately sized residual current devices.



■ Connection to mains supply

The double insulation between the LV power supply and the control conductor on the fixture. Connection to the electricity mains must be carried out by a qualified electrical installer.

Check that the mains frequency and voltage correspond to those for which the projector is designed as given on the electrical data label.

This label also gives the input power to which you need to refer to evaluate the maximum number of fittings to connect to the electricity line, in order to avoid overloading.

Don't use the power cable when the insulation is damaged.

It must be the manufacturer or distributor or the professional person to change the damaged power cable in order to avoid any dangerous.



t_c 80°C



■ **Temperature of the external surface**

The maximum temperature that can be reached on the external surface of the fitting, in a thermally steady state, is 80°C.

Avoid contact by persons and materials.

Allow the fixture to cool for at least 5 minutes before handling.



■ **Maintenance**

Before starting any maintenance work or cleaning the projector, cut off power from the mains supply.



■ **The light source**

The light source in this fixture shall be replaced by the manufacturer or its service agent or similar qualification.

Always disconnect from mains before replacing the light.



■ **Protection against explosion**

The protection screen, lens or ultraviolet screen on the lamp can be damaged to the degree of failure if visible damage, such as a crack or deep mark, should be replaced.

Avoid any inflammable liquids, water or metal objects entering the unit. Once it happens, cut off the mains power immediately.



■ **Protection optical radiation**

Never look directly into the light source. You risk injury to your retina, which may induce blindness.

Do not look at LEDs with magnifiers, telescopes, binoculars or similar optical instruments that may concentrate the light output.



The products referred to in this manual conform to the European Community Directives to which they are subject:

Low Voltage 2014/35/EU

Electromagnetic Compatibility 2014/30/EU

TECHNICAL INFORMATION

- **Power supplies available:**
100-240V ~, 50/60 Hz
- **Rated power:** 1070W PF : 0.96
- **DMX Connector:** IP66 waterproof signal line
- **Power Connector:** IP66 waterproof Power input line
- **Light source:** LUMILEDS 72×15W RGLB (Red, Green, Blue, Lime) LED
- **Average life:** 30000h
- **Luminous flux of light source:** 45550lm
- **Luminaire flux:** 36660lm
- **Lens Angle:** 6°
- **Material of lens:** PMMA
- **Beam Angle:** standard 14°, optional 25° and 45°
- **Vertical tilt Angle:** ±90°
- **CCT:** 2500K -7000K
- **CRI:** Ra≥75
- **Color :**
RGLB macro color system. soft and no flicker, Single ring can be controlled separately, fast marco color system.
- **Strobe :**
1-30 times/second electronic strobe and randomstrobe.
- **Dimmer**
16Bit, 0-100% The linear dimming, provides four dimming options.
- **Control Mode :**
DMX512, RDM, Stand-alone mode , Wireless DMX512 (optional).
- **Channel**
Standard channel:8CH; channel: 40CH、36CH、32CH、1CH、3CH、4CH1、4CH2、5CH、7CH.
- **Display panel:** OLED black and white display.
- **Built-in program:** yes
- **Intelligent temperature control:** yes
- **Software upgrade :** Update via DMX link Channel.
- **RDM:** two-way transmission of RDM data.
- **Data connection:** 3-core waterproof signal transfer input line/output line (5-core waterproof line connector is optional).
Maximum number of signal connections dmx@ 25.
- **Outlooking :** Aluminum alloy,toughenedglass.
- **Surface treatment:** Gray-green fine sand, anti - salt spray corrosion.
- **IP protection level:** Ip66
- **Heat dissipation mode:** natural heat dissipation.
- **Working environment temperature:** - 40 ~ + 45°C
- **Light size:** 916X275X640MM
- **Packing Size (1stes):** 1000X580X500
N.W.: 49.7Kg , G.W.: 67.5Kg
- **Flycase Size(1stes):** 1025X585X655MM
N.W.: 49.7Kg , G.W.: 85.9Kg

Distance, spot diameter and illumination diagram

14° Lux(fc)	R	4106(382)	1223(114)	532(50)	301(28)	140(13)	74(6.9)	58(5.4)
	G	5398(502)	1920(179)	795(74)	480(45)	214(20)	111(10.3)	80(7.4)
	B	806(75)	292(27)	120(11.2)	75(7)	33.5(3.1)	17.7(1.7)	12(1.1)
	L	7197(669)	2705(251)	1077(101)	470(44)	296(27.5)	156(14.5)	117(10.9)
	RBGL	17300(1608)	6000(558)	2480(231)	1500(140)	660(63.3)	352(32.8)	252(23.4)

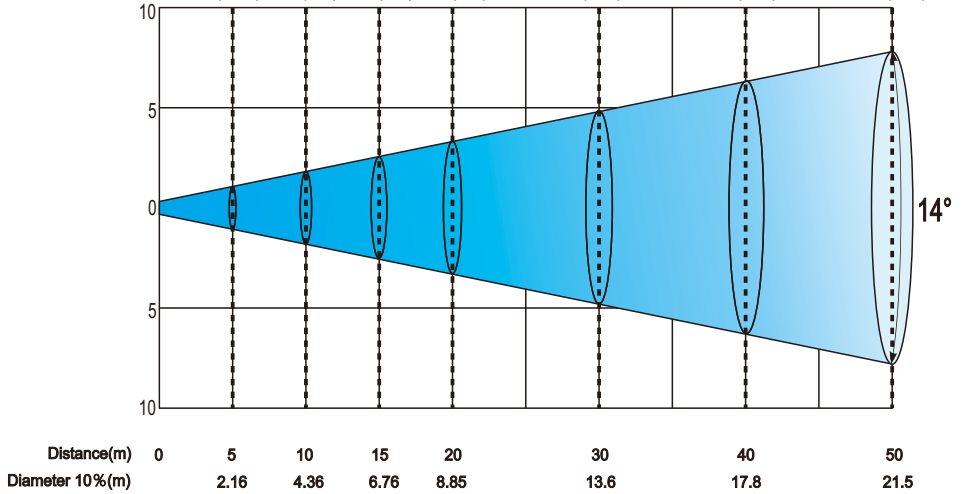

ATTACHMENT AND BODY SIZE

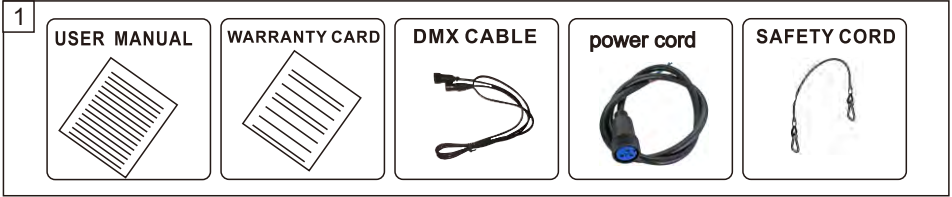

Attachment contents- Fig. 1

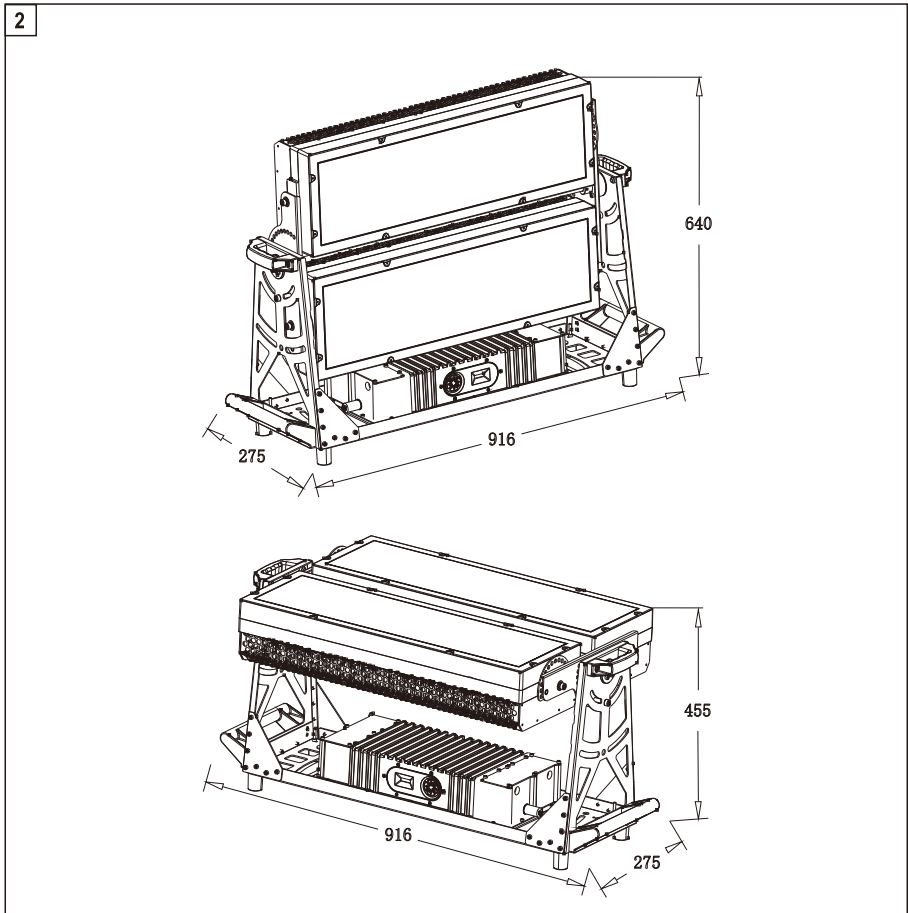

Body Size---Fig 2

INSTALLATION AND CONNECTING

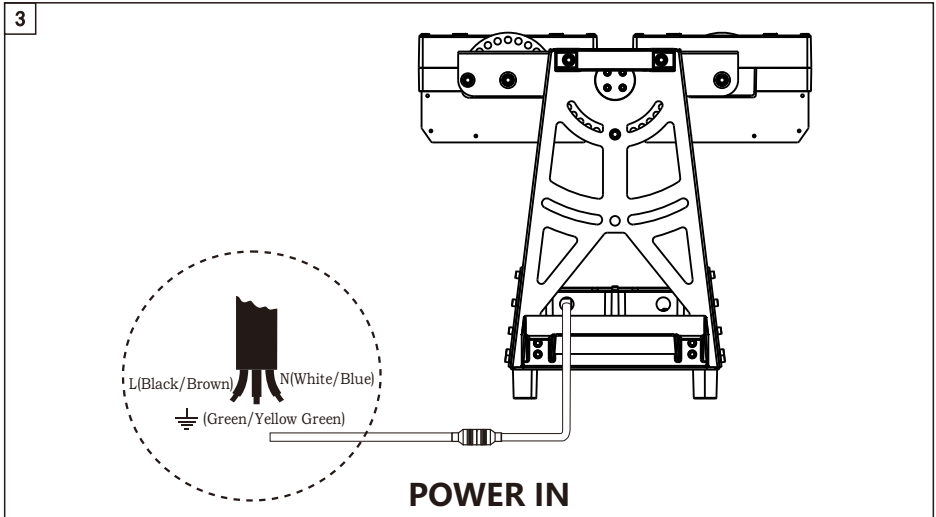

Connecting to the mains supply ---Fig3

Wire color-coding and power connections :

Conductor	Symbol	Wire Color (EU models)	Wire Color (US models)
live	L	brown	black
neutral	N	blue	white
ground(earth)	⊕ or ⊥	yellow-green	green

- connection to the electricity mains must be carried out by a qualified electrical installer.
- After doing the above operation and making sure all the devices had been installed with natural operate, press the power switch to check whether every -thing is working normally.

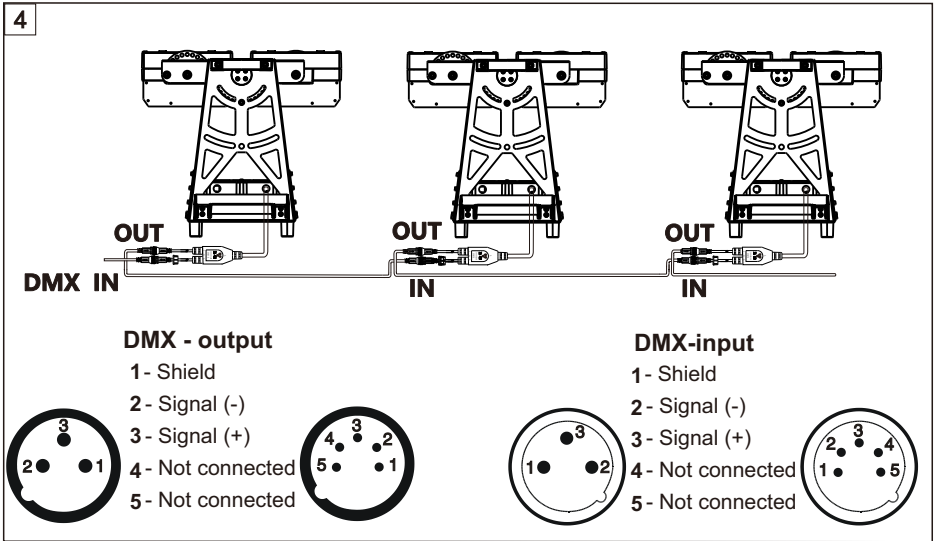

Connecting to the control signal line (DMX) - Fig. 4

© Please use the round 3 or 5-pin XLR plugs & sockets offered by menu factory to connect the first projector's output to the second projector's input and connect the second projector's output to the third projector's input. And in the same way for the rest, eventually connect the last projector's output, all the projectors are together.

© The projectors's control signal output or input by using the 3 or 5-pin XLR plug and socket. If need to lengthen the communication cable, please make sure the both side of 3 or 5-pin plug is one to one (one to one, two to two, three to three). Otherwise, the communication cable will be interrupted. The communication cable is 2-core screened cable 75Ω resistance with each core is at least a 0.5mm diameter. (Caution: All the inside leading wire of 3 or 5-pin XLR plug couldn't touch each other or plinth).

© Recommend to use the DMX signal terminator for the installation to avoid the electronic noise damage the digital control signal. Simply speaking, DMX terminator is an XLR connector with a 120Ω 1/2W resistor connected across pin 2 and 3. Which is then plugged into the output socket on the last projector in the chain. Refer to the connection.

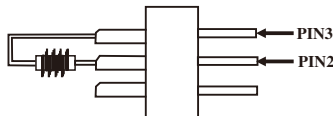

CONTROL PANEL

5

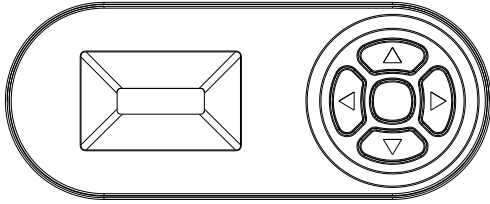

Up arrowhead : page up
Down arrowhead : page down
Left arrowhead : reduce
Right arrowhead : increase
Enter : OK function
Exit : in the choice screen

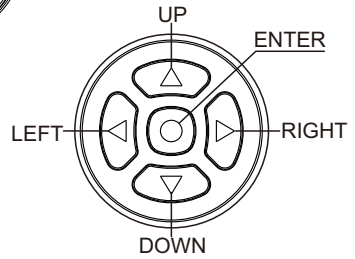

MENU SETTING

Main menu	I menu	II menu	III menu	IV menu	
Dmx Set	Dmx Addr Edit	A001~AXXX			
	DMX Function/功能	Hold			
		Black			
		Red			
		Green			
		Blue			
		Lime			
		Red&Green			
		Red&Blue			
		Red&Lime			
		Green&Blue			
		Green&Lime			
		Blue&Lime			
	Program1~12				
Auto Run Mode	Alone (Default)				
	Master				
Auto Run Sp	Speed = 01--99 (Default : 88)				
Addr Edit (Auto)	Yes/No				
Information	Total Time	Total Time:**** (H)			
		Total LED :**** (H)			
	Fixture Time	Fixture:**** (H)			
		LedOpen:**** (H)			
	Soft Version	V1.00A..			
	Clr Fixture Time	Yes/No			
	DMX Info	Strobe.Dimmer.....			
Box Info	Box Temp= ;/ Humidity= ;/				
RDM Set	RDM UID = xxxxxxxxxxxxx;				
	MANU..LABEL = LIGHTSKY				
	DEVICE LABEL = SUNNY				
Personal Set	Channel Mode	08CH (Default)			
		40CH			
		36CH			
		32CH			
		01CH			
		03CH			
		04CH			
		04CH			
		05CH			
	07CH				
Standby Key Lock	On/Off (Default: Off)				

Main menu	I menu	II menu	III menu	IV menu	
Personal Set	SelectDimmer Hz	Select 24K Hz (Default)			
		Select 12K Hz			
		Select 6K Hz			
		Select 3K Hz			
	DimmerCurve	Linear (Default)			
		Square			
		I-Square			
		SCurve			
Manual Control	Channel	Strobe.Dimmer.....			
Service	Calibration	Red, Green, Blue, White			
	Factory Set	Reset Default (Default)	Yes/No		
		ClearTotalTime	Yes/No		
		Developer	Yes/No	Temp To Power	0n/Off (Default : 0n)
				Manual Or Dmx	0n/Off (Default : 0n)
				LOGO Display	0n/Off (Default : 0n)
				Reset Address	Yes/No
Language	English	(Default)			
	Chinese				
Dis Rotation	Normal	(Default)			
	Rotate 180/				
Temperature	Temp1;Temp2;Temp3;Temp4				
Special key function description:Press UP and DOWN buttons at the same time,keep 3 seconds,Show direction reversal;Press Left and Right buttons at the same time. Hold for 3 seconds and switch between Chinese and English					

CHANNEL FUNCTION

Standardchannel (8CH)

Channel	Value	Percentage	Function	Note
1			Shutter	
	0..9		No function	
	10..255		Strobe effect slow to fast	
2			Dimmer	
	0..255		Dimmer 0%..100%	
3			Red	
	0..255		0-100% Red dimmer from dark to bright	
4			Green	
	0..255		0-100% Green dimmer from dark to bright	
5			Blue	
	0..255		0-100% Blue dimmer from dark to bright	
6			Lime	
	0..255		0-100% Lime dimmer from dark to bright	
7			Pixel Macro	
	0..4		No function	
	5..28		Macro 1	
	29..55		Macro 2	
	53..76		Macro 3	
	77..100		Macro 4	
	101..124		Macro 5	
	125..148		Macro 6	
	149..172		Macro 7	
	173..196		Macro 8	
	197..220		Macro 9	
	221..244		Macro 10	
	245..250		Macro 11	
251..255		Macro 12		
8			Macro Speed	
	0..255		Macro Speed from slow to fast	

Note: After the address batch modification is successful, the lights will turn on red, green, blue and lemon in turn, and finally strobe twice, and then switch back to the original light state.

channel (40CH)

Channel	Value	Percentage	Function	Note
1			Shutter	
	0..9		No function	
	10..255		Strobe effect slow to fast	
2			Dimmer	
	0..255		Dimmer 0%..100%	
3			Red	
	0..255		0-100% Red dimmer from dark to bright	
4			Green	
	0..255		0-100% Green dimmer from dark to bright	
5			Blue	
	0..255		0-100% Blue dimmer from dark to bright	
6			Lime	
	0..255		0-100% Lime dimmer from dark to bright	
7			Pixel Macro	
	0..4		No function	
	5..28		Marcro 1	
	29..55		Marcro 2	
	53..76		Marcro 3	
	77..100		Marcro 4	
	101..124		Marcro 5	
	125..148		Marcro 6	
	149..172		Marcro 7	
	173..196		Marcro 8	
	197..220		Marcro 9	
	221..244		Marcro 10	
	245..250		Marcro 11	
251..255		Marcro 12		
8			Macro Speed	
	0..255		Macro Speed from slow to fast	
9			Red in Pixel 1	
	0..255		Red in pixel 1 saturation control (0-100%)	
10			Green in Pixel 1	
	0..255		Green in pixel 1 saturation control (0-100%)	
11			Blue in Pixel 1	
	0..255		Blue in pixel 1 saturation control(0-100%)	
12			Lime in pixel 1	
	0..255		Lime in pixel 1 saturation control(0-100%)	

Channel	Value	Percentage	Function	Note
13			Red in pixel 2	
	0..255		Red in pixel 2 saturation control(0-100%)	
14			Green in pixel 2	
	0..255		Green in pixel 2 saturation control(0-100%)	
15			Blue in pixel 2	
	0..255		Blue in pixel 2 saturation control(0-100%)	
16			Lime in pixel 2	
	0..255		Lime in pixel 2 saturation control(0-100%)	
17			Red in Pixel 3	
	0..255		Red in pixel 3 saturation control (0-100%)	
18			Green in pixel 3	
	0..255		Green in pixel 3 saturation control(0-100%	
19			Blue in pixel 3	
	0..255		Blue in pixel 3 saturation control(0-100%)	
20			Lime in pixel 3	
	0..255		Lime in pixel 3 saturation control(0-100%)	
21			Red in Pixel 4	
	0..255		Red in pixel 4 saturation control (0-100%)	
22			Green in pixel 4	
	0..255		Green in pixel 4 saturation control(0-100%)	
23			Blue in pixel 4	
	0..255		Blue in pixel 4 saturation control(0-100%)	
24			Lime in pixel 4	
	0..255		Lime in pixel 4 saturation control(0-100%)	
25			Red in Pixel 5	
	0..255		Lime in pixel 5 saturation control (0-100%)	
26			Green in pixel 5	
	0..255		Green in pixel 5 saturation control(0-100%)	
27			Blue in pixel 5	
	0..255		Blue in pixel 5 saturation control(0-100%)	
28			Lime in pixel 5	
	0..255		Lime in pixel 5 saturation control(0-100%)	
29			Red in Pixel 6	
	0..255		Lime in pixel 6 saturation control (0-100%)	
30			Green in pixel 6	
	0..255		Green in pixel 6 saturation control(0-100%)	
31			Blue in pixel 6	
	0..255		Blue in pixel 6 saturation control(0-100%)	

Channel	Value	Percentage	Function	Note
32			Lime in pixel 6	
	0..255		Lime in pixel 6 saturation control (0-100%)	
33			Red in Pixel 7	
	0..255		Lime in pixel 7 saturation control (0-100%)	
34			Green in pixel 7	
	0..255		Green in pixel 7 saturation control (0-100%)	
35			Blue in pixel 7	
	0..255		Blue in pixel 7 saturation control (0-100%)	
36			Lime in pixel 7	
	0..255		Lime in pixel 7 saturation control (0-100%)	
37			Red in Pixel 8	
	0..255		Lime in pixel 8 saturation control (0-100%)	
38			Green in pixel 8	
	0..255		Green in pixel 8 saturation control (0-100%)	
39			Blue in pixel 8	
	0..255		Blue in pixel 8 saturation control (0-100%)	
40			Lime in pixel 8	
	0..255		Lime in pixel 8 saturation control (0-100%)	

channel (36CH)

Channel	Value	Percentage	Function	Note
1			Shutter	
	0..9		No function	
	10..255		Strobe effect slow to fast	
2			Dimmer	
	0..255		Dimmer 0%..100%	
3			Pixel Macro	
	0..4		No function	
	5..28		Macro 1	
	29..55		Macro 2	
	53..76		Macro 3	
	77..100		Macro 4	
	101..124		Macro 5	
	125..148		Macro 6	
	149..172		Macro 7	
	173..196		Macro 8	
	197..220		Macro 9	
	221..244		Macro 10	
	245..250		Macro 11	
251..255		Macro 12		
4			Macro Speed	
	0..255		Macro Speed from slow to fast	
5			Red in Pixel 1	
	0..255		Red in pixel 1 saturation control (0-100%)	
6			Green in Pixel 1	
	0..255		Green in pixel 1 saturation control (0-100%)	
7			Blue in Pixel 1	
	0..255		Blue in pixel 1 saturation control(0-100%)	
8			Lime in pixel 1	
	0..255		Lime in pixel 1 saturation control(0-100%)	
9			Red in pixel 2	
	0..255		Red in pixel 2 saturation control(0-100%)	
10			Green in pixel 2	
	0..255		Green in pixel 2 saturation control(0-100%)	
11			Blue in pixel 2	
	0..255		Blue in pixel 2 saturation control(0-100%)	
12			Lime in pixel 2	
	0..255		Lime in pixel 2 saturation control(0-100%)	

Channel	Value	Percentage	Function	Note
13			Red in Pixel 3	
	0..255		Red in pixel 3 saturation control (0-100%)	
14			Green in pixel 3	
	0..255		Green in pixel 3 saturation control (0-100%)	
15			Blue in pixel 3	
	0..255		Blue in pixel 3 saturation control (0-100%)	
16			Lime in pixel 3	
	0..255		Lime in pixel 3 saturation control (0-100%)	
17			Red in Pixel 4	
	0..255		Red in pixel 4 saturation control (0-100%)	
18			Green in pixel 4	
	0..255		Green in pixel 4 saturation control (0-100%)	
19			Blue in pixel 4	
	0..255		Blue in pixel 4 saturation control (0-100%)	
20			Lime in pixel 4	
	0..255		Lime in pixel 4 saturation control (0-100%)	
21			Red in Pixel 5	
	0..255		Lime in pixel 5 saturation control (0-100%)	
22			Green in pixel 5	
	0..255		Green in pixel 5 saturation control (0-100%)	
23			Blue in pixel 5	
	0..255		Blue in pixel 5 saturation control (0-100%)	
24			Lime in pixel 5	
	0..255		Lime in pixel 5 saturation control (0-100%)	
25			Red in Pixel 6	
	0..255		Lime in pixel 6 saturation control (0-100%)	
26			Green in pixel 6	
	0..255		Green in pixel 6 saturation control (0-100%)	
27			Blue in pixel 6	
	0..255		Blue in pixel 6 saturation control (0-100%)	
28			Lime in pixel 6	
	0..255		Lime in pixel 6 saturation control (0-100%)	
29			Red in Pixel 7	
	0..255		Lime in pixel 7 saturation control (0-100%)	
30			Green in pixel 7	
	0..255		Green in pixel 7 saturation control (0-100%)	
31			Blue in pixel 7	
	0..255		Blue in pixel 7 saturation control (0-100%)	

Channel	Value	Percentage	Function	Note
32			Lime in pixel 7	
	0..255		Lime in pixel 7 saturation control (0-100%)	
33			Red in Pixel 8	
	0..255		Lime in pixel 8 saturation control (0-100%)	
34			Green in pixel 8	
	0..255		Green in pixel 8 saturation control (0-100%)	
35			Blue in pixel 8	
	0..255		Blue in pixel 8 saturation control (0-100%)	
36			Lime in pixel 8	
	0..255		Lime in pixel 8 saturation control (0-100%)	

channel (32CH)

Channel	Value	Percentage	Function	Note
1			Red in Pixel 1	
	0..255		Red in pixel 1 saturation control (0-100%)	
2			Green in Pixel 1	
	0..255		Green in pixel 1 saturation control (0-100%)	
3			Blue in Pixel 1	
	0..255		Blue in pixel 1 saturation control(0-100%)	
4			Lime in pixel 1	
	0..255		Lime in pixel 1 saturation control(0-100%)	
5			Red in pixel 2	
	0..255		Red in pixel 2 saturation control(0-100%)	
6			Green in pixel 2	
	0..255		Green in pixel 2 saturation control(0-100%)	
7			Blue in pixel 2	
	0..255		Blue in pixel 2 saturation control (0-100%)	
8			Lime in pixel 2	
	0..255		Lime in pixel 2 saturation control (0-100%)	
9			Red in Pixel 3	
	0..255		Red in pixel 3 saturation control (0-100%)	
10			Green in pixel 3	
	0..255		Green in pixel 3 saturation control(0-100%	
11			Blue in pixel 3	
	0..255		Blue in pixel 3 saturation control(0-100%)	
12			Lime in pixel 3	
	0..255		Lime in pixel 3 saturation control(0-100%)	
13			Red in Pixel 4	
	0..255		Red in pixel 4 saturation control (0-100%)	
14			Green in pixel 4	
	0..255		Green in pixel 4 saturation control(0-100%)	
15			Blue in pixel 4	
	0..255		Blue in pixel 4 saturation control(0-100%)	
16			Lime in pixel 4	
	0..255		Lime in pixel 4 saturation control (0-100%)	
17			Red in Pixel 5	
	0..255		Lime in pixel 5 saturation control (0-100%)	
18			Green in pixel 5	
	0..255		Green in pixel 5 saturation control(0-100%)	
19			Blue in pixel 5	
	0..255		Blue in pixel 5 saturation control(0-100%)	

Channel	Value	Percentage	Function	Note
20			Lime in pixel 5	
	0.255		Lime in pixel 5 saturation control(0-100%)	
21			Red in Pixel 6	
	0.255		Lime in pixel 6 saturation control (0-100%)	
22			Green in pixel 6	
	0.255		Green in pixel 6 saturation control (0-100%)	
23			Blue in pixel 6	
	0.255		Blue in pixel 6 saturation control(0-100%)	
24			Lime in pixel 6	
	0.255		Lime in pixel 6 saturation control(0-100%)	
25			Red in Pixel 7	
	0.255		Lime in pixel 7 saturation control (0-100%)	
26			Green in pixel 7	
	0.255		Green in pixel 7 saturation control(0-100%)	
27			Blue in pixel 7	
	0.255		Blue in pixel 7 saturation control(0-100%)	
28			Lime in pixel 7	
	0.255		Lime in pixel 7 saturation control(0-100%)	
29			Red in Pixel 8	
	0.255		Lime in pixel 8 saturation control (0-100%)	
30			Green in pixel 8	
	0.255		Green in pixel 8 saturation control (0-100%)	
31			Blue in pixel 8	
	0.255		Blue in pixel 8 saturation control(0-100%)	
32			Lime in pixel 8	
	0.255		Lime in pixel 8 saturation control(0-100%)	

channel (1CH)

Channel	Value	Percentage	Function	Note
1			ALL Dimmer	
	0..255		Dimmer 0%..100% Control all LED	

channel (3CH)

Channel	Value	Percentage	Function	Note
1			Red	
	0..255		0-100% Red dimmer from dark to bright	
2			Green	
	0..255		0-100% Green dimmer from dark to bright	
3			Blue	
	0..255		0-100% Blue dimmer from dark to bright	

channel (4CH 1)

Channel	Value	Percentage	Function	Note
1			Dimmer	
	0..255		Dimmer 0%..100%	
2			Red	
	0..255		0-100% Red dimmer from dark to bright	
3			Green	
	0..255		0-100% Green dimmer from dark to bright	
4			Blue	
	0..255		0-100% Blue dimmer from dark to bright	

channel (4CH 2)

Channel	Value	Percentage	Function	Note
1			Red	
	0..255		0-100% Red dimmer from dark to bright	
2			Green	
	0..255		0-100% Green dimmer from dark to bright	
3			Blue	
	0..255		0-100% Blue dimmer from dark to bright	
4			Lime	
	0..255		0-100% Lime dimmer from dark to bright	

channel (5CH)

Channel	Value	Percentage	Function	Note
1			Dimmer	
	0..255		Dimmer 0%..100%	
2			Red	
	0..255		0-100% Red dimmer from dark to bright	
3			Green	
	0..255		0-100% Green dimmer from dark to bright	
4			Blue	
	0..255		0-100% Blue dimmer from dark to bright	
5			Lime	
	0..255		0-100% Lime dimmer from dark to bright	

channel (7CH)

Channel	Value	Percentage	Function	Note
1			Shutter	
	0..9		No function	
	10..255		Strobe effect slow to fast	
2			Dimmer	
	0..255		Dimmer 0%..100%	
3			Red	
	0..255		0-100% Red dimmer from dark to bright	
4			Green	
	0..255		0-100% Green dimmer from dark to bright	
5			Blue	
	0..255		0-100% Blue dimmer from dark to bright	
6			Lime	
	0..255		0-100% Lime dimmer from dark to bright	
7			Pixel Function	
	0..10		No function	
	11..30		Red 100%/Green Up/Blue 0%	
	31..50		Red Down/Green 100%/Blue 0%	
	51..70		Red 0 %/Green 100%/Blue Up	
	71..90		Red 0 %/Green Down/Blue 100%	
	91..110		Red Up/Green 0%/Blue 100%	
	111..130		Red 100%/Green 0%/Blue Down	
	131..150		Red 100%/Green Up/Blue Up	
	151..170		Red Down/Green Down/Blue 100%	
	171..200		Red100%/Green 100%/Blue 100%	
	201..210		White 3200K	
	211..220		White 4200K	
	221..230		White 5600K	
231..240		White 6500K		
241..250		White 8000K		
251..255		White 10000K		

CIRCUIT CONNECTING DIAGRAM

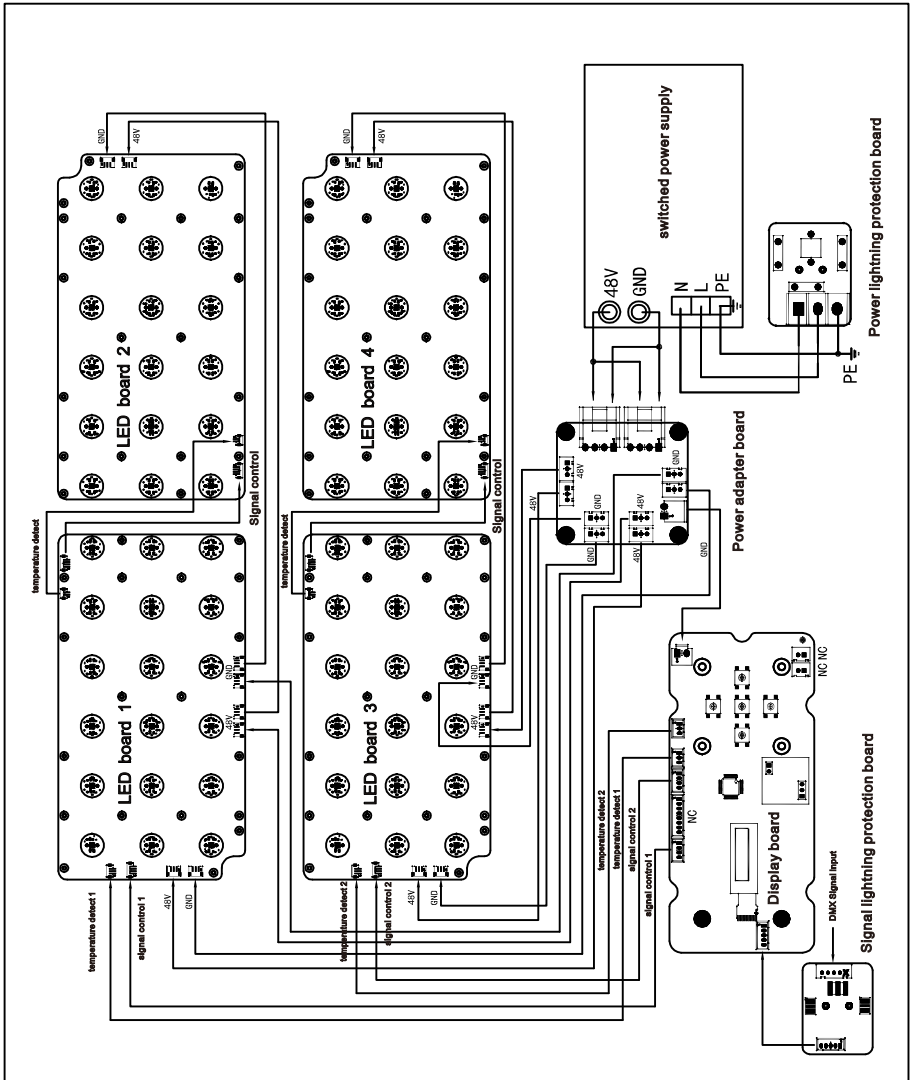

CLEANING AND MAINTENANCES

- 1. In order to ensure the projector could work normally. It should be kept clean always .
The lens should also be regularly cleaned to maintain an optimum light output.
Do not use any type of solvent on lens. It will damage the projector.

- 2. Suggestion: The continue usage of the light don't exceed 4 hours. Or it will shorter the usage of the lamp. Please use the alternative operation to solve this problem.
The fixture power ON time is best not over 48 hours, or it would generate lamp protection procedure.

- 3. Please disconnect the power supply when begin to maintenance take down the light.
Please let the parts cool down 10 minute at least then begin to install.

- 4. Please inspect the lens or other moving parts timing and keep them clear and static.
If find anything damaged or looseness must change a lamp or fix the lamp in order to avoid the accident.
Please check the machanical parts is jamging. After cleaning, please add some temperature -durable juice.

- 5. The light use the strong cool system. It is easy for the dirty to be colleted. Please do clear the hot-sak one time two week at least.

- 6. After you use the light, please check the intake place whether there are some wastepaper, please clean it up, or the windmill will break down and causing fire.

CAUTION!

Disconnect from mains before starting maintenance operation.

TROUBLESHOOTING

It is recommended some solution for some normal trouble shooting. Any inextricability problems should always be handling by the professional person. Disconnect the power supply before maintenance the light.

■ LED o / LED :

- 1.Please check if install the suitable voltage.
- 2.Please check whether the led will reach the end of their life can explode; please replace a same description led.
- 3.Please check if the power supply is enough.
- 4.Please check whether the DMX 512 controller pass the "turn on" order.

■The light couldn't accept the control order:

- 1.Please check the start code address and the function option are correct.
- 2.Please check whether the communicate control cable is on good connection or the cable is too long or interrupt.
- 3.Please check the control system is not valid, check the signal amplifier of chain connected is valid.
- 4.Please check whether the communicate cable is too long or the other equipment is mutually conjugate.
- 5.Please arrange the wire well, shorter the signal cable, put the high voltage cable and low voltage cable separately.
- 6.Add the signal amplify isolator.
- 7.Signal cable is used the excellent screening doublet (Resistance 75 OHM) .
- 8.The end of the light end and the end resistance.

■The light can't move:

- 1.Please check if the power supply is suitable for the light voltage data.
- 2.Please check the light if they are deformation, inside parts is broken, become wet etc will lead the loose contact.
- 3.Please check the if the inside lead wire and the connector is loose.
- 4.Please check the electric parts(such as the transformer,PCB board,contrller) is short-circuit or burn down.

■

On working,the pan &tilt couldn't work normally:

1. Please check according to the above step by step.
2. Please check the belt of the X.Y is broken.
3. Please check the X/Y direction data to the receiver is damage.
4. Re-projector reset.

DUTY EXONERATIVE AND COPYRIGHT PROTECTION

- ◇The lamp belongs to consumption products that is not guarantee to keep it in good repair.
- ◇Any products broken that didn't according to the instruction is not guarantee to keep it in good repair.
- ◇The commentary for all the instruction belongs to the supplier in final.
- ◇No authorize can't copy.
- ◇The information in this manual may be changed in the future,the company reserve the right to change the data without any advise.