

TLP Pro 1025T

10" TABLETOP TOUCHLINK PRO TOUCHPANEL



The Extron TLP Pro 1025T is a 10" tabletop TouchLink® Pro Touchpanel with many enhanced features. Extron redesigned this latest TouchLink Pro Touchpanel inside and out with a new, high-performance quad-core processor, eight times more memory, a higher resolution, 1280x800 capacitive touchscreen built with scratch and smudge-resistant Corning® Gorilla Glass®, and a distinctive enclosure with a sleek, gracefully-sweeping back. The TLP Pro 1025T also features the convenience of PoE - Power over Ethernet, which allows it to receive power and communication over a single Ethernet cable.

- ▶ 10" capacitive edge-to-edge glass touchscreen with 1280x800 resolution and 24-bit color depth
- ▶ Newly designed inside and out for the ideal balance of performance and style
- ▶ Gorilla Glass® screen is tough, scratch and smudge-resistant
- ▶ Faster, quad-core processing and eight times more memory
- ▶ Compatible with all IP Link Pro control processors
- ▶ Power over Ethernet provides power and communication over a single Ethernet cable
- ▶ Light sensor adjusts screen brightness as the ambient room lighting changes

DESCRIPTION

The **TLP Pro 1025T** is a 10" tabletop touchscreen that offers stellar performance and superior design. Inside, there's a powerful new quad-core processor and eight times more memory feeding the high resolution 1280 x 800 capacitive touchscreen. The touchscreen, itself, is our most durable yet - built with scratch and smudge-resistant Corning Gorilla Glass. Outside you'll find a stylish, ergonomic enclosure that will complement any contemporary presentation environment.

A host of familiar features provides elegant, simple operation, while PoE, Power over Ethernet streamlines integration by allowing the touchpanel to receive power and communication over a single Ethernet cable.

All TouchLink Pro touchpanels can be customized using Extron GUI Designer software. This powerful interface design software offers ready-to-use templates for a wide variety of rooms and presentation environments.

PANEL DRAWINGS

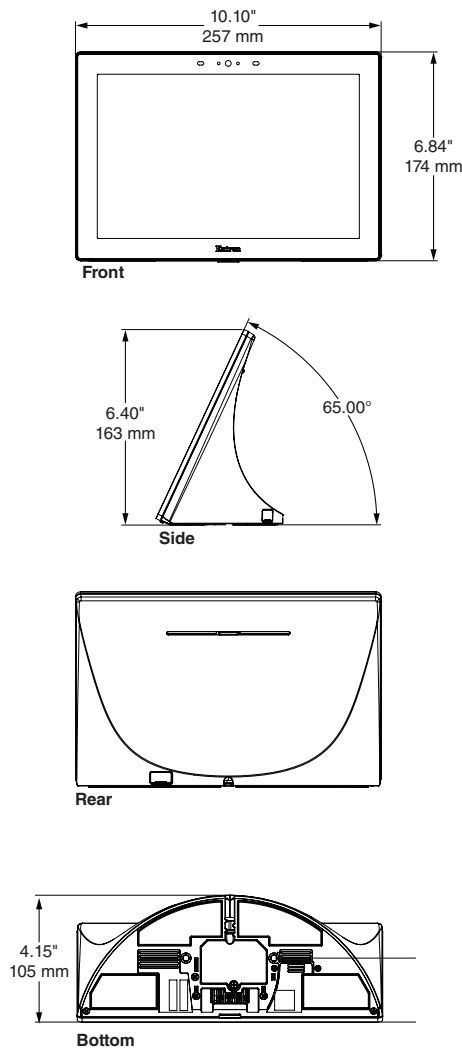

SPECIFICATIONS

DISPLAY		
Screen type	TFT Active matrix Color LCD	
Size	10.1" (25.7 cm), measured diagonally	
Resolution	1280x800	
Aspect ratio	Widescreen	
Color depth	24 bit, 16.7 million colors	
Contrast	800:1	
Backlight	LED	
Viewing angle	±85° horizontal, ±85° vertical	
Touch screen	Capacitive	
MEMORY		
SDRAM	2 GB	
Flash	4 GB	
COMMUNICATION – ETHERNET INTERFACE		
Ethernet control/communications port	1 female RJ-45 connector	
Ethernet data rate	10/100/1000Base-T, half/full duplex with autodetect	
Ethernet protocol	DHCP, DNS, HTTP, HTTPS, ICMP, SFTP, SSH, TCP/IP, UDP/IP	
CONTROL – USB		
Number/signal type	1 high-speed USB 2.0 device	
AUDIO OUTPUT		
Speaker output	1 mono, 86 dB SPL, 0.1 watt, 0.1 m, half space	
Playback format(s)		
Container format	WAV (Microsoft RIFF)	
Encoding	LPCM (uncompressed)	
Bit depth	Unsigned 8-bit Signed 16-bit Signed 24-bit Signed 32-bit	
Sampling rate	Up to 192 kHz	
Audio channels	mono or stereo	
GENERAL		
Power supply	Not included	
Power input requirements	Power over Ethernet (PoE 802.3af, class 3)	
Auxiliary power output		
USB	5 VDC, 275 mA	
Temperature/humidity	Storage: -4 to +158 °F (-20 to +70 °C) / 5% to 90%, noncondensing Operating: -4 to +158 °F (-20 to +70 °C) / 20% to 90%, noncondensing	
Mounting	Set on a tabletop	
Enclosure dimensions	6.84" H x 10.10" W x 4.15" D (174 mm H x 257 mm W x 105 mm D)	
Regulatory compliance		
Safety	CE, c-UL, UL	
EMI/EMC	CE, C-Tick, FCC Class A, ICES, KCC, VCCI	
Environmental	Complies with the appropriate requirements of RoHS and WEEE.	
Warranty	3 years parts and labor; touchpanel display and overlay components are covered for 1 year	
Model	Version Description	Part number
TLP Pro 1025T	Black - Tabletop	60-1565-02
TLP Pro 1025T	White - Tabletop	60-1565-03

For complete specifications, please go to www.extron.com
Specifications are subject to change without notice.

WORLDWIDE SALES OFFICES

Anaheim • Raleigh • Silicon Valley • Dallas • New York • Washington, DC • Toronto • Mexico City • Paris • London
Frankfurt • Madrid • Stockholm • Amersfoort • Moscow • Dubai • Johannesburg • Tel Aviv • Sydney • Melbourne
Bangalore • Mumbai • New Delhi • Singapore • Seoul • Shanghai • Beijing • Hong Kong • Tokyo

www.extron.com