

Specifications

TLP Pro 725C Series

Display

Screen type	TFT Active matrix color LCD
Size	7" (17.8 cm), measured diagonally
Resolution.....	1024x600 (WSVGA)
Pixel density.....	170 PPI
Aspect ratio	17:10
Color depth.....	24 bit, 16.7 million colors
Transparency	8 bit
Brightness	420 nits (cd/m ²)
Contrast.....	700:1
Backlight.....	LED
Viewing angle.....	±75° horizontal, +70°/-75° vertical
Touch screen	Capacitive

Memory

RAM	2 GB
Storage.....	4 GB

Ethernet

Connectors.....	1 female RJ-45 connector
Data rate.....	10/100/1000Base-T, half/full duplex with autodetect
Protocols	DHCP, DNS, HTTP, HTTPS, ICMP, SFTP, SSH, TCP/IP, UDP/IP
Default settings	Link speed and duplex level = autodetected IP address = 192.168.254.251 Subnet mask = 255.255.255.0 Default gateway = 0.0.0.0 DHCP = off DNS = 127.0.0.1

Software

Configuration software	Global Configurator Plus and Professional, GUI Designer
Programming software.....	Global Scripter
Control apps.....	Extron Control, iGVE
Resource management software.....	GlobalViewer Enterprise, iGVE
Utilities	Toolbelt, Embedded web page

Sensors

Motion sensor	On/off
Light sensor.....	Auto/manual
Lid switch	Open/closed

USB

Quantity/type	1 high-speed USB 2.0 device
Connectors.....	1 USB type A connector
Standards.....	USB 2.0, USB 1.1, USB 1.0 compatible
Max. data rates.....	Low speed (1.5 Mbps), full speed (12 Mbps), high speed (480 Mbps)

Audio output

Speaker output	1 mono, 89 dB Max. SPL @ 0.1 m
Frequency response	750 Hz to 20 kHz, ± 5 dB
Playback format(s)	
Container format	WAV (Microsoft RIFF)
Encoding	LPCM (uncompressed)
Bit depth	Unsigned 8-bit Signed 16-bit Signed 24-bit Signed 32-bit
Sampling rate	Up to 192 kHz
Audio channels.....	Mono or stereo

General

Power supply	Not included
Power input requirements	Power over Ethernet (PoE 802.3af, class 3)
Power consumption — Power injector (XTP PI 100)	
Device	TBD watts
Device and power injector	TBD watts
Auxiliary power output	
USB	5 VDC, 275 mA
Temperature/humidity	Storage: -4 to +140 °F (-20 to +60 °C) / 10% to 90%, noncondensing Operating: +32 to +104 °F (0 to +40 °C) / 10% to 90%, noncondensing
Cooling	Convection
Thermal dissipation — Power injector (XTP PI 100)	
Device	TBD BTU/hr
Device and power injector	TBD BTU/hr
Mounting	Furniture mount
Enclosure type	Metal

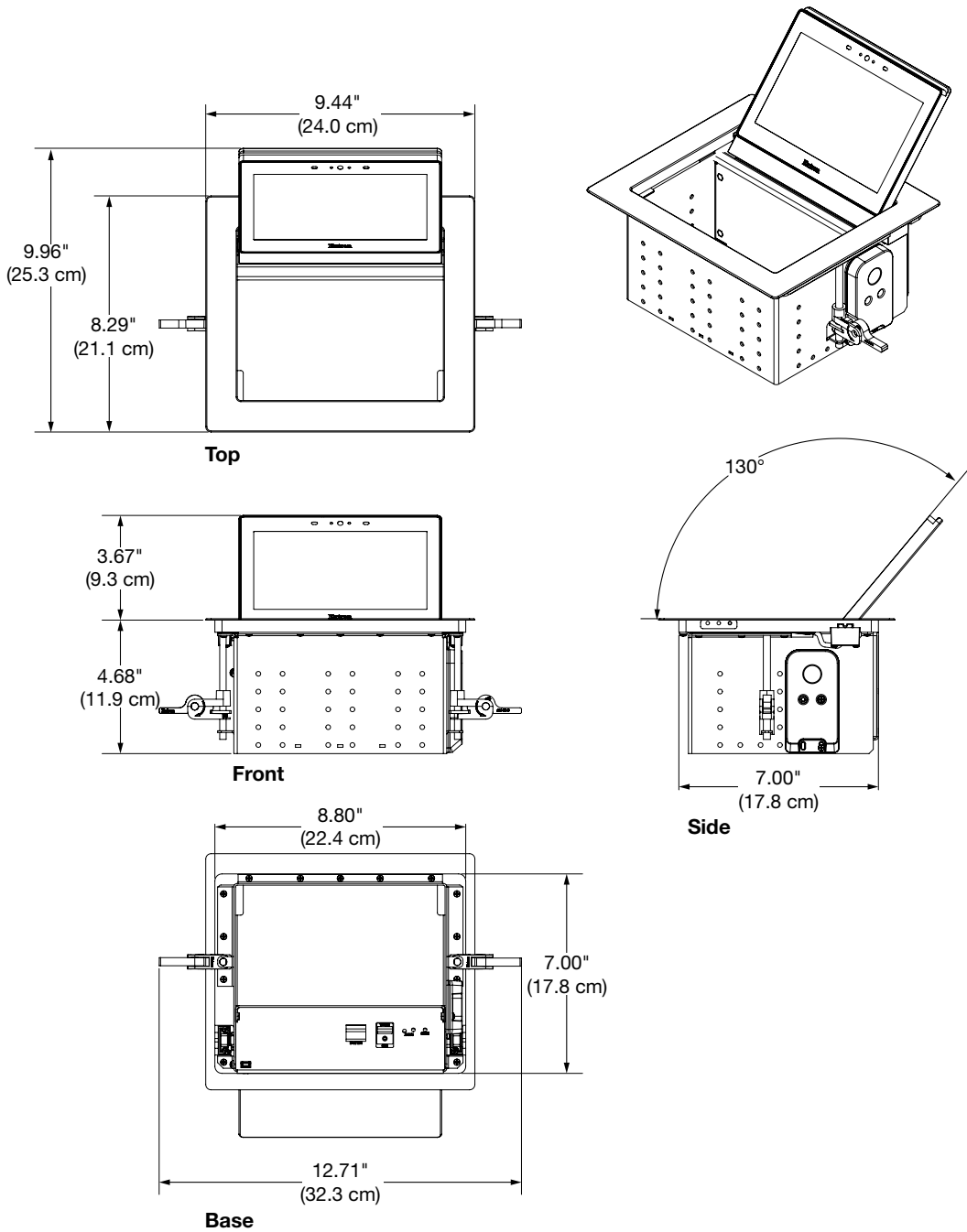

Enclosure dimensions

ATTENTION: Use the appropriate metal Extron routing template or refer to the surface cutout dimensions here before cutting a hole in the furniture or other surface. Pay special attention to the direction the unit will face; the unit's connector access side is underlined. Extron is not responsible for miscut mounting holes.

- Top plate (outer rim)..... 9.44" W x 8.29" D
(24.0 cm W x 21.1 cm D)
- Surface cutout (inside rim) 8.80 +0.00/-0.02" W x 7.00 +0.00/-0.02" D
(22.4 +0.00/-0.05 cm W x 17.8 +0.00/-0.05 cm D)
- Box (under surface) 4.68" H x 12.71" W (front/rear of unit) x 7.00" D with clamps
(11.9 cm H x 32.3 cm W x 17.8 cm D with clamps)

Retractor Mounting Clearance

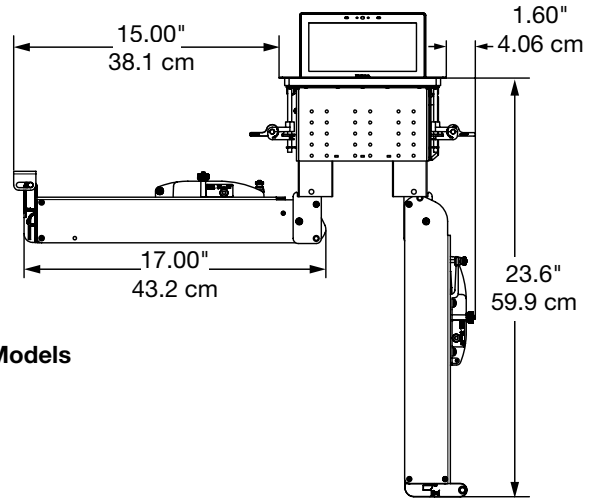

Standard Models

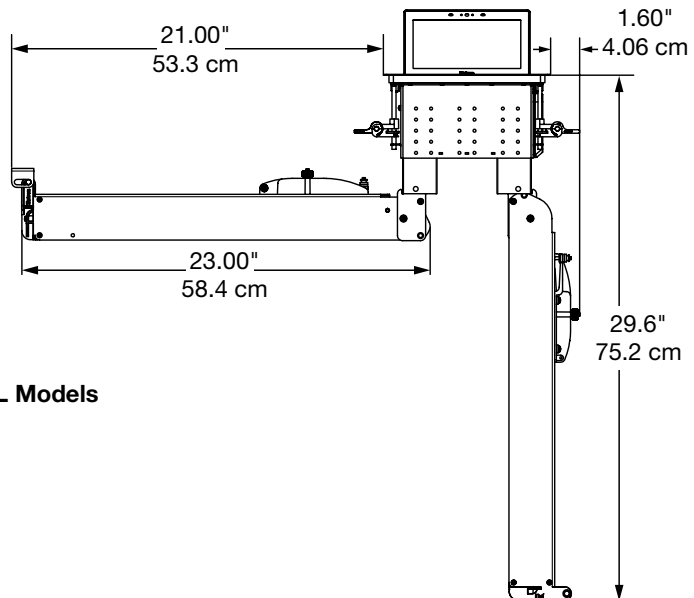

XL Models

Product weight	TBD lb (TBD kg)
Regulatory compliance.....	CE, C-Tick, c-UL, FCC Class B, ICES, RoHS, UL, VCCI, WEEE
Warranty	3 years parts and labor; touchpanel display and overlay components are covered for 1 year

NOTES:

- All nominal levels are at $\pm 10\%$.
- Specifications are subject to change without notice.
- Shipping dimensions and weights are available at www.extron.com.