

# Tornado-KT2|KT2C

2" point source multipurpose loudspeaker



**Tornado-KT2**



**Tornado-KT2CW**

DATASHEET

Installed Sound Tornado-KT2|KT2C

## DESCRIPTION

The Tornado series is a miniature sound source designed for high-quality distributed systems.

Housed in a compact aluminum enclosure, the Tornado is suitable for space sensitive and architectural design installations.

The Tornado is a turnkey loudspeaker solution: designed as passive speakers that can be easily converted into self-powered devices by inserting the KA1-T2 12V/24V amplifier module. Tornados have a proprietary 2" high-efficiency drive unit with a neodymium magnet structure and a

suspension engineered for maximum linear excursion and minimum residual transducer interference. The cone transducer delivers an impressive maximum peak SPL of 107 dB, and has a wide operating frequency range from 150 Hz to 18 kHz with very low distortion.

With its ability to effortlessly reproduce both speech and music, it makes an excellent choice for fixed applications such as theatre, museum displays, restaurants, portable systems for corporate AV presentations, department stores, and in hidden locations

such as chancel steps in houses of worship. The KT2 and KT2W models come with a wall bracket for fixed installations or surface applications while the KT2C and KT2CW come with a ceiling brackets for ceiling mounts.

All Tornado components are designed by the K-array R&D department and custom made under the K-array quality control system. Designed as passive speaker, the Tornados can be easily converted into a self-powered device by inserting the KA1-T2H 12V/24V amplifier module.

## COLORS & PREMIUM FINISHES AVAILABLE



Black



White



Custom

## SUGGESTED ACCESSORIES

KA1-T2H

K-AL75

K-AL15

K-AL120

K-AL66

K-AL240

## FREQUENT APPLICATIONS

CAFES, BISTROS & RESTAURANTS

HOTELS

RETAIL

THEME PARKS

TRANSPORTION FACILITIES

MUSEUMS

AUDITORIUMS, EDUCATION & GOVERNMENT

BROADCAST & STUDIOS

## FEATURES



Visually Discreet



Weather Resistant



Electronically Protected



Selectable Impedence

# TECHNICAL SPECIFICATIONS

ACOUSTICS	
Power handling	18 W <sup>(AES)</sup>
Impedance	8Ω - 32Ω (settable) 70V version available upon request (KT2-HV)
Frequency range (-10 dB)	150 - 18 kHz <sup>(1)</sup>
Maximum SPL	101 dB (cont.) - 107 dB (peak) <sup>(2)</sup>
COVERAGE	
Horizontal	90°
Vertical	90°
CROSSOVER	
Type	External Crossover required
Frequency	150Hz 24dB/Oct minimum required
TRANSDUCERS	
Full-range	2" Neodymium magnet Woofer with 2 voice coils of 0.8"
Impedance	2 x 16 Ω
POWER AUDIO INPUT	
Connectors	4-pin Phoenix connector
Wiring	VoiceCoil A=1+ 1- VoiceCoil B=2+ 2-
CERTIFICATION	
IP	54
EVAC	EN54-24
PHYSICAL OVERVIEW	
Dimensions	7.4 x 12.1 x 11.7 cm (2.93"x 4.76"x 4.62") <sup>(3)</sup> KT2 12,5 x 12,5 x 11,9 cm (4.92"x 4.92"x 4.68") <sup>(3)</sup> KT2C
Weight	0.6 Kg (1.32 lb)
<p>Notes for data</p> <ol style="list-style-type: none"> <li>With dedicated preset;</li> <li>Measured @8 m, then scaled @1 m;</li> <li>( W x H x D).</li> </ol> <p>New materials and design are introduced into existing products without previous notice. Present systems may differ in some respects from those presented here catalogue.</p>	

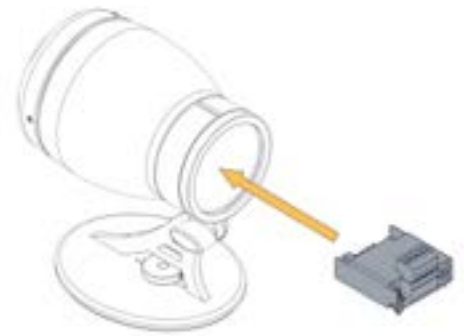

KT2+KA1-T2H

